

ASHLY

ASHLY AUDIO, INC.

SC40 INSTRUMENT PREAMP



The SC-40 was developed to provide ultra clean pre-amplification for a guitar, bass, keyboard or other high or low impedance sources with an operating level between -50 and +10 dBV (nominal operating level is -20). Even when the SC-40 is intentionally driven to distortion the overload characteristic is one of "clean" clipping free from spikes or transients.

FEATURES:

- High and low level inputs
- Master in/out effects loop
- Semi-parametric Equalization
- Separate level controls for stage and PA feeds
- Rugged 16 gauge steel chassis
- Peak overload light
- Instrument level, Mic level and two line level outputs



A wide range of instruments can be accommodated with the 0 to +30 dB range of the input gain control. A send and return loop follows the input gain amp, the return being a balanced input.

There is a selection of two output level controls. The stage output is post-Eq and is for use with on-stage amplifiers. The PA output, for the house system or recording console input, is pre/post-Eq switchable. PA outputs for both line level and balanced mic level are provided.

Tone control is accomplished by a three band semi-parametric equalizer. The high and low Eq sections are shelving controls with variable frequency turn-over points. The mid section is a peaking control with variable frequency. The entire unit is monitored at several key points by the peak detector. Any signal level within the unit reaching +14 dB or greater fires the peak LED.

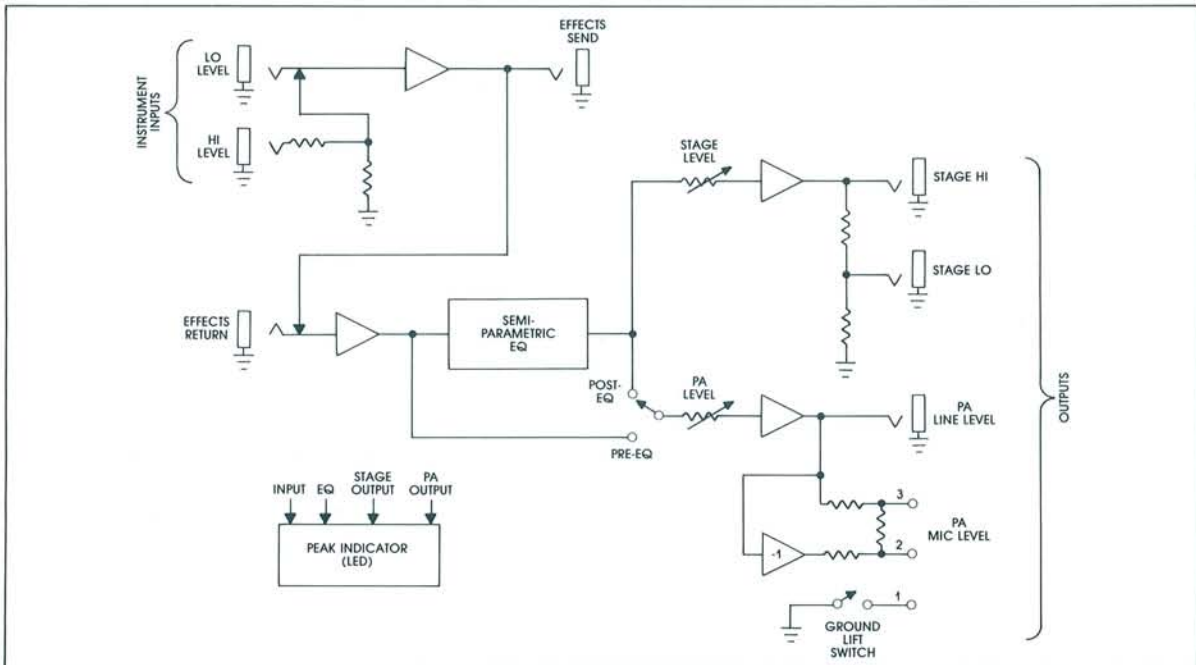

SPECIFICATIONS:

CONTROLS	
gain	0 - +40dB
equalization	
low boost-cut	±15dB
low frequency (shelf)	30 - 300Hz
mid boost-cut	±15dB
mid frequency (peak)	160Hz-8kHz
high boost-cut	±15dB
high frequency (shelf)	750Hz-8kHz
output level	
PA	-∞ - +20dB
STAGE	-∞ - +26dB
pre-post eq. select	(PA output)
ground lift switch	(rear panel)
INPUT IMPEDANCE	
Main	2.2 megΩ unbalanced
Echo return	10kΩ balanced bridging line level
OUTPUT IMPEDANCE	
Echo send	600Ω unbalanced line level

Stage	
High	100Ω unbalanced line level
Low	600Ω unbalanced -20dBV
PA	
Line	100Ω unbalanced line level
MIC	600Ω balanced mic level with ground lift
MAX. IN-OUT LEVEL	+20dBm
FREQUENCY RESPONSE	±5dB 20Hz-20kHz
DISTORTION	< .05% THD, +10dBV 20Hz-20kHz
HUM AND NOISE	(unity gain)
PA Line and Stage	
High outputs	-85dV
PA Mic and Stage	
Low outputs	-105dV
POWER	120 VAC, 50-60Hz, 5W
SIZE	19"L x 1 3/4"H x 6"D
SHIPPING WEIGHT	8 lbs.