

ASHLY

Gated Compressor/ Limiter

model CG-85E

Five-Year
Worry-Free Warranty



Ashly is a pioneer in the field of automatic gain reduction, long known for producing limiter-compressors that achieve powerful regulation of peak levels with minimal side effects. The **CG-85E** represents the culmination of years of experience in this field, combining proven Ashly gain-control technology with built-in intelligence to completely eliminate the undesirable side effects of the limiting process previously thought unavoidable. Absolute freedom in adjustment of all dynamic parameters allows the action of the **CG-85E** to be tailored to any application, and low noise and low distortion assure that your signal stays clean and quiet.

Traditionally, most automatic gain controls have been relatively simple devices, merely reducing the gain when threshold levels were exceeded and increasing it again later. While there have been many improvements in the VCA circuits which produce the actual gain change, most limiters and compressors still use fairly simple detectors to tell the VCA what to do. A fast-acting peak limiter, which acts on only a few really hot bursts, is acceptable if all that is needed is a little reduction of occasional quick transients. It is the compression application, where constant changes of gain occur, which requires more sophistication. The Ashly **CG-85E** provides complete access to its dynamic parameters, allowing you total control over all compressor and limiter functions, making it an indispensable tool for studio, broadcast, and pro-sound applications.

In the design of any automatic gain-control device, listening tests provide the best criteria because the changes in gain are DYNAMIC actions which cannot be described by conventional steady-state audio measurements. In addressing the need to discriminate between long-term

overload and quick transients such as mic pops and record scratches, a dual release time constant was utilized in our detector so that a long overdrive could result in a slow release for unobtrusive action, but short transients wouldn't cause pumping and breathing.

The result of conventional compression on program material with pauses is obvious. As the gain increases during the pause, room noise, hum and hiss also increase. When the signal resumes, the gain must be abruptly reduced, making the compressor's presence very much known. Circuitry which utilizes a noise gate to simply "shut off" the signal entirely during a pause is clearly inadequate because it produces an extreme gain change which, in itself, is very audible. The **CG-85E** adds logic to the release function to address this problem. When the signal falls below an adjustable threshold level the release action is stopped. The **CG-85E** handles gain adjustments like a human operator would, reducing gain when the signal is too loud, increasing it when needed, and leaving it alone if it is not worth changing.

Another less obvious problem with fast releasing peak limiters is distortion of low frequency signals. The detector actually releases slightly between individual low frequency cycles necessitating a re-attack at each peak, hence squaring it off. In essence, the attack and release functions constantly fight each other and change gain at every cycle. Additional release logic in the **CG-85E** gates off the release function until there has not been an attack for 50 milliseconds, thereby preventing this problem and its resulting distortion.

The Ashly **CG-85E** will make a dramatic difference in your audio processing abilities, providing you with virtually unlimited possibilities. Plus, all Ashly products are now covered by our exclusive five-year worry-free warranty.

Independent Attack,
Release and Ratio
Adjustment

Adjustable Attack and
Release Thresholds

20 Segment Gain
Reduction Indicator

10 Segment Meter for
Input or Output Level

Gated Release
Function to Minimize
'Breathing'

Distortion Reducing
Release Logic
Circuitry

Dual Time Constant
Release for
Natural Action

Stereo Tie and Side
Chain Patch Points

Specifications

CONTROLS
 Defeat Switch
 Gated Release Defeat Switch
 Meter Select Switch
 Gain: +15dB
 Ratio: 2:1-∞
 Attack Time: 200μS. - 20mS.
 Release Time: 100mS. - 2S.
 Attack Threshold: -12dBV - +20dBV
 Release Threshold: -30dBV - +6dBV

Input Impedance: 10kΩ balanced bridging
 Output Impedance: 200Ω terminated w/600Ω or more
 Detector Patch Point: Allows the connection of an equalizer in the detector loop to produce frequency selective limiting
 Maximum Input/Output Level: ±20dBm
 Frequency Response: +5dB 20Hz - 20kHz
 Distortion: <.05%THD, 0dBV 20Hz - 20kHz no limiting
 <.2% +18dBV worst case
 Hum and Noise: -90dBV, unity gain
 Power Requirements: 120VAC, 50-60Hz, 5W
 Size: 19"L x 1.75"H x 6"D
 Shipping Weight: 8 lbs.

Block Diagram

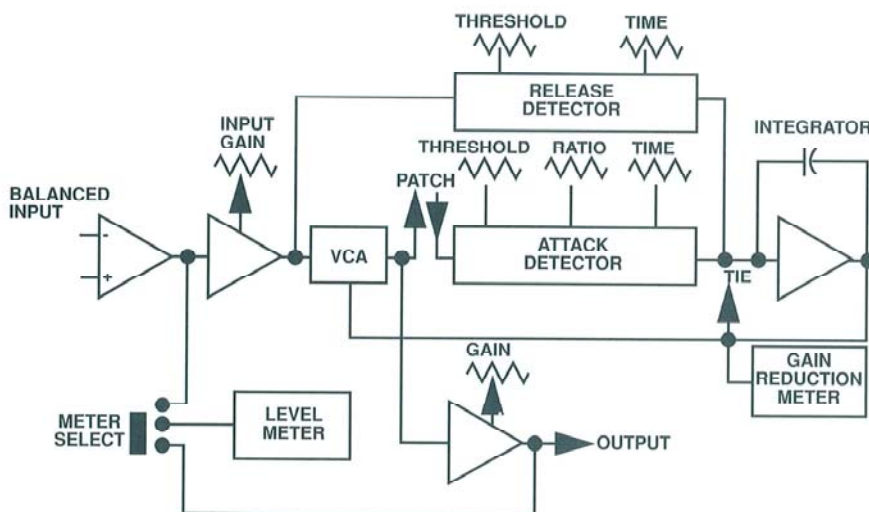

Architect's Specification

The unit shall be a single channel gated compressor-limiter with independent attack, release and ratio adjustments. It shall have adjustable attack and release thresholds. Performance specifications of a typical production unit shall meet or exceed the following: gain control shall be ±15 dB. The ratio shall be adjustable from 2:1 to ∞. The attack time shall be adjustable from 200 μS to 20 mS. The release time shall be adjustable from 100 mS to 2S. The attack threshold shall be adjustable from -12dBV to +20dBV. The release threshold shall be adjustable from -30dBV to +6dBV. The input impedance shall be 10kΩ (balanced bridging). The output impedance shall be 200Ω, terminated with 600Ω or more. It shall have detector patch points which allow the connection of an external equalizer in the detector loop to produce frequency selective limiting. Its maximum in-out level shall be ±20dBm. The frequency response shall be ±5dB from 20Hz to 20kHz. Distortion shall be <.05% THD @ 0dBV from 20Hz to 20kHz with no limiting, <.2% @ +18dBV worst case. Hum and noise shall not exceed -90dBV @ unity gain. The unit shall operate from 115V± 5% 50-60Hz. The unit shall be designed for mounting in a standard EIA 19" rack (19"L x 1.75"H x 6"D) and shall have a shipping weight of 8lbs. The unit shall be a model CG-85E Gated Compressor Limiter manufactured by Ashly Audio Inc. No other unit shall be acceptable unless submitted data from an independent test laboratory verifies that the above combined size/performance specs are met.

Ashly Audio Inc.

ASHLY

Since 1972

© 1990 Ashly Audio