

# ASHLY

## VC Series

VCX-80 - Eight Channel Remote Level Control  
VCM-88 - Eight Channel Matrixing Level Controller  
RD-8 - Desktop Remote  
RW-8 - Wall Mount Remote

## Operating Manual

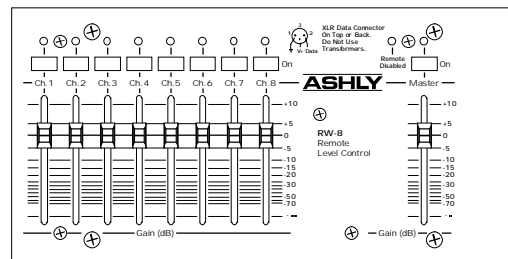
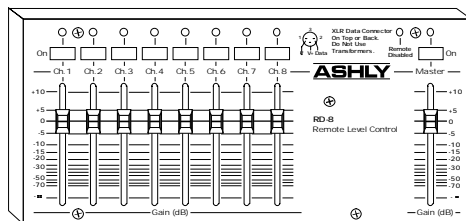
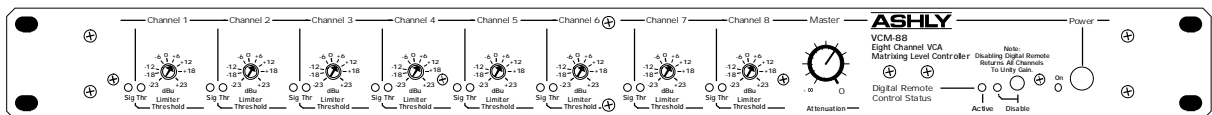
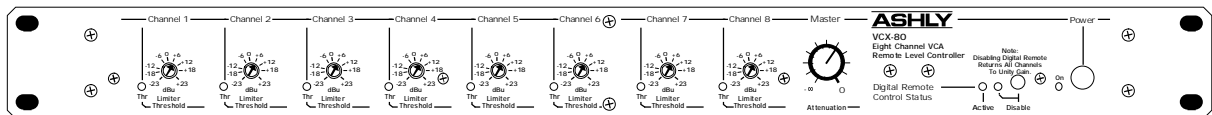

### ASHLY AUDIO INC.

847 Holt Road Webster, NY 14580-9103 Phone: (716) 872-0010  
Toll-Free: (800) 828-6308 Fax: (716) 872-0739 Internet: [www.ashly.com](http://www.ashly.com)

# Table Of Contents

<b>1</b>	<b>Introduction</b>	<b>3</b>
<b>2</b>	<b>Unpacking</b>	<b>3</b>
<b>3</b>	<b>AC Power Requirements</b>	<b>3</b>
<b>4</b>	<b>Security Covers</b>	<b>3</b>
<b>5</b>	<b>VCX-80 Digital Remote Control System</b>	<b>4</b>
	5.1 Limiter Threshold	
	5.2 Master Attenuation	
	5.3 Digital Remote Control Status Active Indicator	
	5.4 Digital Remote Control Disable Switch	
	5.5 Power Switch	
	5.6 Master Output and Channel Pass Through	
	5.7 DC Control	
	5.8 AMX and Crestron Control	
	5.9 Bank Select	
<b>6</b>	<b>VCM-88 Matrixing Remote Controller</b>	<b>5</b>
	6.1 Signal Present LED	
	6.2 Input Matrixing	
	6.3 RS-232 Input	
	6.4 MIDI	
<b>7</b>	<b>RD-8/RW-8 Remote</b>	<b>6</b>
	7.1 Channel and Master On Switch	
	7.2 Channel and Master Fader	
	7.3 Remote Disable Indicator	
	7.4 Data Connection	
<b>8</b>	<b>Audio Connections and Cables</b>	<b>7</b>
	8.1 Balanced and Unbalanced Signals	
	8.2 Input Connections	
	8.3 Output Connections	
	8.4 Single Jack TRS Insert	
	8.5 Master Output	
	8.6 Single Channel Pass-Through	
	8.7 Input Matrixing (VCM-88 only)	
<b>9</b>	<b>Data Connections and Configurations</b>	<b>9</b>
	9.1 Remote XLR Data Connection	
	9.2 AMX and Crestron	
	9.3 DC Control Voltage Connection	
	9.4 RS-232 Control and Protea System Software (VCM-88 only)	
	9.5 MIDI Implementation (VCM-88 only)	
<b>10</b>	<b>Troubleshooting Tips</b>	<b>10</b>
<b>11</b>	<b>Warranty Information</b>	<b>11</b>
<b>12</b>	<b>Technical Specifications</b>	<b>11</b>
<b>13</b>	<b>Dimensional Drawings and Schematics</b>	<b>12</b>
<b>14</b>	<b>Common Applications</b>	<b>15</b>

## 1. Introduction

One of the many useful circuits to be developed for audio use is the VCA, or *voltage controlled amplifier*. A VCA circuit allows for accurate, low distortion level control without signal degradations sometimes encountered when using mechanical controls or long signal paths. VCA circuits can be found in compressor/limiter/expanders, noise gates, noise reduction systems, automatic mixers, VCA-Bus consoles, and other places where remote control or fast automatic system response is required. Designers at Ashly felt there was still a need for high quality VCA control which could be incorporated into professional sound systems without unnecessarily high cost or complication.

The Ashly VCX-80 provides eight fully-independent VCA channels in a single unit capable of limiting, remote level control, and mixing. When connected to the Ashly RD-8 Remote Controller or DC control, the VCX-80 controls individual channel and master levels with a range of -75dB to +20dB. Each VCA channel has separate input and output jacks for patching into line-level signal paths, and can be reconfigured to use single jack TRS insertion for patching into mixing consoles. When using the VCX-80 as a mixer (master output), each channel's input can be configured to "pass-through" to its output for daisy chaining multiple units together.

The Ashly VCM-88 takes all the features of the VCX-80 and adds Signal Present LEDs on each channel, a dedicated RS-232 computer interface, full MIDI implementation, and Input Matrixing, which allows the user to internally jump any input to one or more other inputs.

The RD-8 remote controller is a compact slide-fader remote level controller which can be desk-top situated or rack-mounted into two rack spaces (3.5 inches) using the RD8-RM optional mounting bracket. This remote controller is also available as the RW-8 for wall-mounting into a standard 4-gang electrical box. The RD-8 controls the audio levels of the VCX-80 over a standard XLR snake cable or mic cable. As it is powered entirely by the VCX-80, no batteries or remote power supply are necessary for either RD-8 or RW-8. The RD-8 can communicate to the VCX-80 over a 24 gauge snake cable in excess of 1/4 mile. The RD-8 also pulse-shapes the digital waveform to eliminate digital crosstalk noise into adjacent audio channels.

## 2. Unpacking

As a part of our system of quality control, every Ashly product is carefully inspected before leaving the factory to ensure flawless appearance. After unpacking, please inspect for any physical damage. Save the shipping carton and all packing materials, as they were carefully designed to reduce to minimum the possibility of transportation damage should the unit again require packing and shipping. In the event that damage has occurred, immediately notify your dealer so that a written claim to cover the damages can be initiated.

The right to any claim against a public carrier can be forfeited if the carrier is not notified promptly and if the shipping carton and packing materials are not available for inspection by the carrier. Save all packing materials until the claim has been settled.

## 3. AC Power Requirements

A standard IEC-320 AC inlet is provided on the rear panel to accept the detachable power cord shipped with the unit. Units distributed within the United States are preselected for 120VAC, 60Hz and should be plugged into a standard NEMA 5-15 3-wire grounded AC receptacle. Most units distributed outside the US are preselected and labeled for 240VAC, 50-60Hz and are shipped with the appropriate power cord.

The VCX-80 and VCM-88 will perform normally from 98 to 125 volts AC. An internal line fuse is used. In the event of fuse failure, refer to a qualified service technician for servicing. Maximum power consumption of the VCX-80 and VCM-88 is 18 watts.

## 4. Security Covers

For installations where it is desirable to protect the front panel controls from tampering or accidental misadjustment, use the Ashly security cover, which is available in both single and double rack space sizes. Installation is simple and does not require removal of the equipment from your rack. See your Ashly dealer for details.

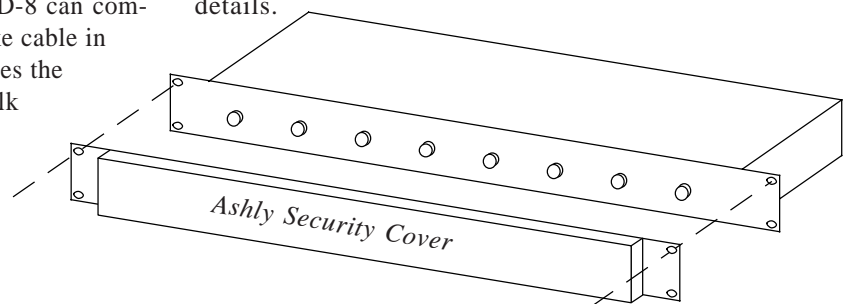

Ashly Security Cover Installation

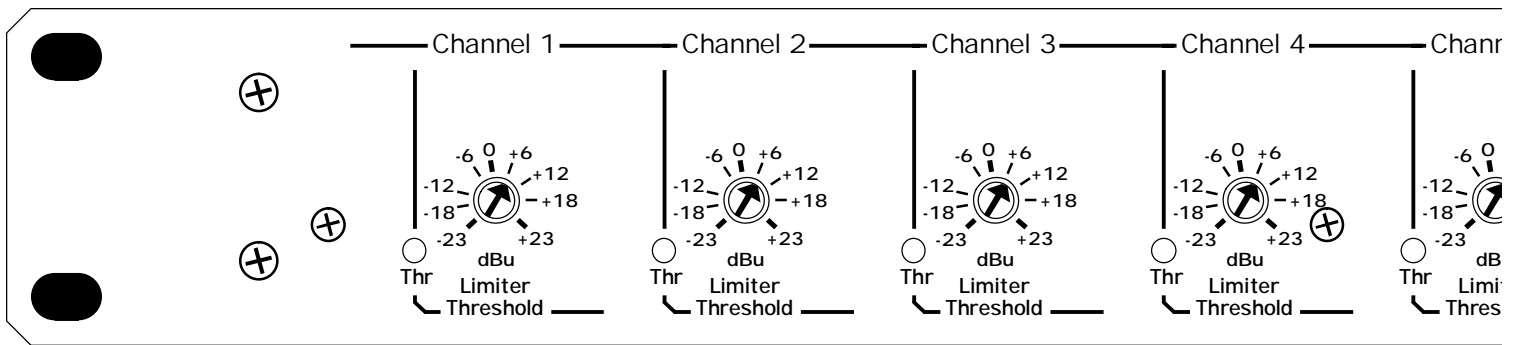

## 5. VCX-80 Digital Remote Control Features

### 5.1 Limiter Threshold

The recessed Limiter Threshold trimpot adjusts the signal threshold above which the limiter will become active. The units of this threshold dial are dBu where 0dBu = 0.775Vrms. The limiter is a peak-detecting true VCA-type limiter with very low distortion. The input to output ratio of the limiter is approximately 10 to 1 with a relatively fast attack and moderate release time behavior. The adjacent yellow threshold LED indicates when the limiter circuit has been activated by an audio signal above the threshold level. *To disable the limiter on any given channel, simply rotate its threshold adjustment fully clockwise to +23dBu, which is the maximum input signal of the unit.*

### 5.2 Master Attenuation

This control attenuates all eight channels uniformly, and was designed as a simple means of turning-down all eight audio channels at the VCX-80 location in the event of feedback or other sound system problems. *Normally this control should be set fully clockwise at 0dB attenuation.*

### 5.3 Digital Remote Control Status Indicator

This green LED indicates when the VCX-80 is receiving data from the RD-8 or RW-8. If this light goes out, it means the VCX-80 is no longer receiving data, due to a disconnection of the control data signal. In the event of remote control data interruption, the VCX-80 will "remember" all settings just before the data reception stopped and continue to operate as if there were no changes happening. Reconnecting the remote data signal with the VCX-80 still operating will instantly change the channel level settings to wherever the controller is currently set. *Note: If the VCX-80 AC power is switched on with no data reception, all eight channels and the master level will default to unity gain (0dB).*

### 5.4 Digital Remote Control Disable Switch

This switch disables the RD-8 remote controller and returns all eight channels to unity gain. The adjacent red LED indicates when this switch is depressed. The nearby green Remote Active indicator will go off when the remote is disabled because the RD-8 does not send any data when it is disabled. After releasing the remote disable switch, all channels return to their respective levels set by the RD-8 remote controller.

### 5.5 Power Switch

This front-panel push-button switches the AC power to the unit. The adjacent green LED indicates when the unit is powered on. If the green LED does not light, check to see if the unit is plugged into a live outlet, and that the removable AC cord is firmly plugged into the VCX-80. If there is still no light, refer the unit to a qualified service technician.

### 5.6 Master Output and Channel Pass Through

The VCX-80 can be used as an eight-in/one-out remote level control for personal monitor mixing using the Master Output. Multiple VCX-80 units can be daisy-chained to produce several unique mixes from the same program source. To simplify cabling for this application, the VCX-80 has the ability to internally pass each channel's input signal directly to its output jack, disabling

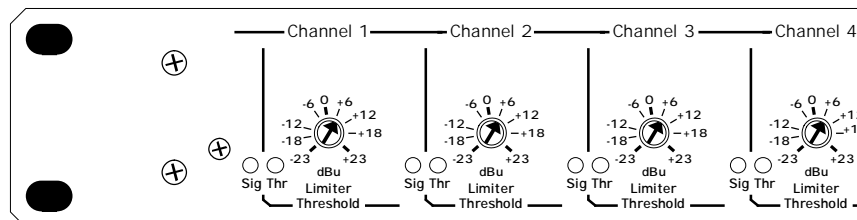

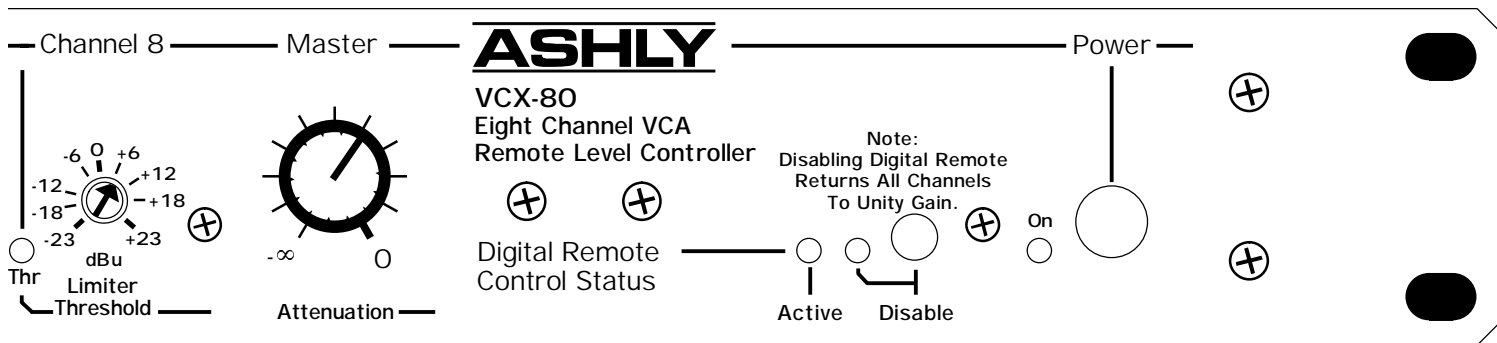

that channel's direct VCA output but eliminating the need for special "Y" cables. The passed-through channel's VCA output is automatically summed to the Master Output along with other channels for final output. See section 8.6 for channel pass-through details.

### 5.7 DC Control

A 15 pin female D-Sub connector on the back panel is used for DC control of the eight VCA channels and Master Attenuation, providing a simple and cost-effective method for custom control of the VCX-80. Most electronics hardware stores will have the male connector complement. The reference DC voltage is also provided, thus requiring only the male D-Sub connector, wire, and a 10K ohm potentiometer for each channel to control audio levels from any reasonable distance. See section 9.3 for DC Control details.

### 5.8 AMX and Crestron Control

AMX and Crestron are companies which manufacture touch-screen computer interfaces for a variety of control applications, including professional audio equip-

ment. The Ashly VCX-80 is used in such systems to easily and remotely control audio levels of multiple sources in a corporate, aesthetically pleasing environment. AMX provides a hardware interface which uses the XLR Data In connector. Crestron also uses the XLR data connector, however an internal jumper selection on the VCX-80 must be properly set to accept the Crestron data format. See section 9.2 for AMX and Crestron interface details.

### 5.9 Bank Select

Each VCX-80 can be internally addressed to one of 32 banks, allowing for control of up to 256 channels (32 x 8) from a single data line. Due to data format limitations however, only 16 banks can be defined for use with MIDI, Crestron, or RS-232 control. AMX controllers can access all 32 banks. See section 9.5 for Bank Select jumper locations.

## 6. VCM-88 Matrixing Remote Controller

*All features and functions of the VCX-80 are included in the VCM-88 (shown below), with the addition of the following features:*

- Signal Present LED
- Input Matrixing
- RS-232 Control
- MIDI Control

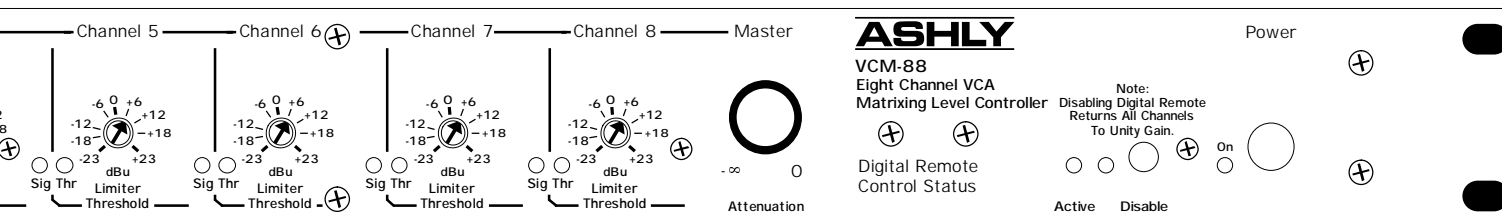

(VCM-88 Features, cont.)

### 6.1 Signal Present LED

Each channel has a green LED to indicate *input* signal present (app. -17dBu). Since the LED is referencing the audio signal *prior* to the VCA circuit, the LED will continue flashing even if the channel level is turned down.

### 6.2 Input Matrixing

Input Matrixing means that an input can be internally routed to one or more additional channel inputs, particularly useful in distributed zone applications. Each of the matrixed VCA channels share a common input signal but retain their distinct level controls via the RD-8, RW-8, or other hardware or software controllers. See section 8.7 for Input Matrixing details.

### 6.3 RS-232 Input

RS-232 is a serial communications protocol which allows computer devices to control other hardware. Ashly Protea System Software (see section 9.4) uses RS-232 to control the VCM-88, and other third party sources may use RS-232 as well. The VCM-88 has a dedicated RS-232 input on a D-Sub 9 pin female connector. An internal jumper selection is required to operate under RS-232 control. See section 9.4 for RS-232 details.

### 6.4 MIDI

MIDI (Musical Instrument Digital Interface) is included as another way of controlling the VCM-88. MIDI In and MIDI Thru jacks allow complete implementation in a MIDI network. An internal jumper selection is required to operate under MIDI control. For specific details regarding internal selection, as well as continuous controller numbers and values, see section 9.5.

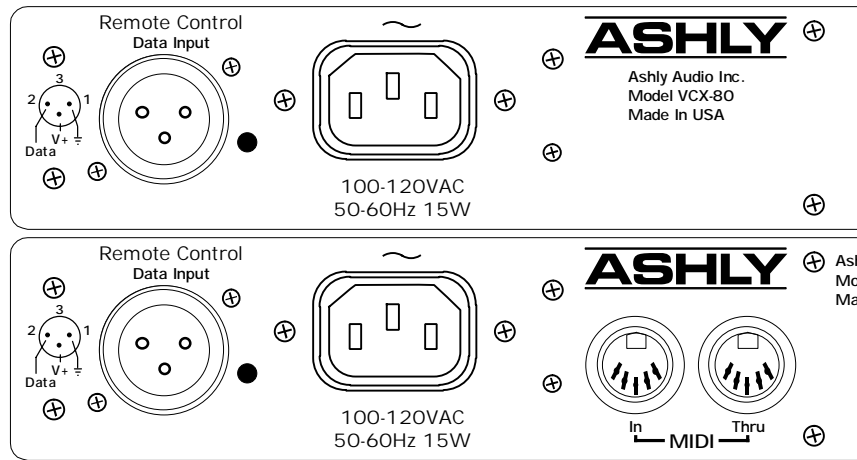

### 7.1 RD-8/RW-8 Channel and Master On Switch

These push-buttons switch the respective VCX-80 channel on or off. When switched on, the channel gain is controlled by the setting of the respective channel fader on the RD-8. When switched off, the respective VCX-80 channel is muted to approximately -75dB by the internal VCA circuit. The adjacent green LED is lit when the channel is switched on.

### 7.2 RD-8/RW-8 Channel and Master Fader

These slide faders control the gain (volume) in dB of their respective channel in the VCX-80. The Master fader controls the gain of all eight channels together. That is to say, the master fader can raise or lower all eight channels uniformly without affecting the “mix” just like the master fader on a mixing console.

### 7.3 RD-8/RW-8 Remote Disable Indicator

This red LED illuminates when the RD-8 has been disabled by the Remote Disable Switch on the VCX-80. When the Remote Disable LED goes off, the RD-8 remote

## 7. RD-8/RW-8 Remote

*The RD-8 and RW-8 are functionally the same. The difference is that the RW-8 is designed to mount as a wall plate using a standard 4-gang electrical box. Both the VCX-80 and VCM-88 respond identically to the RD-8 or RW-8.*

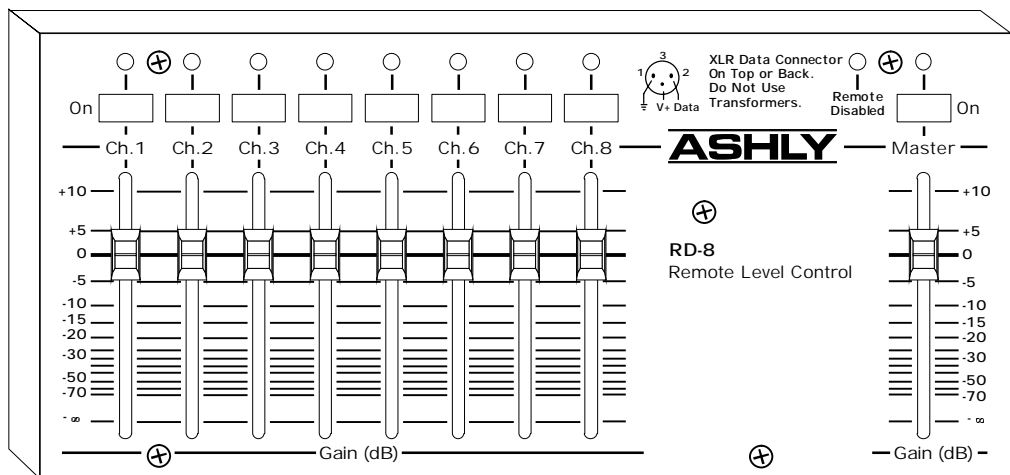

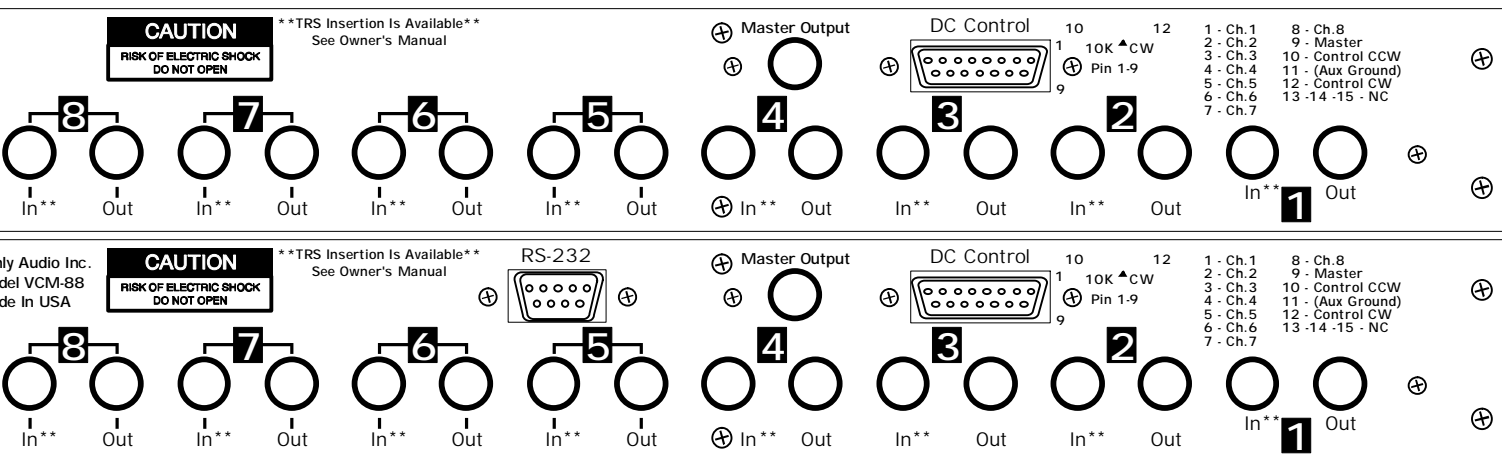

controller will resume normal operation. Avoid dramatically changing the level settings of the controller when disabling it or disconnecting the data line, as the VCX-80 master will immediately respond to any changes made to the controller upon re-connecting.

#### 7.4 RD-8/RW-8 Data Connection

The male XLR jacks on the side and bottom of the RD-8 are wired in parallel so that an XLR plug may be inserted into the side for desktop operation or into the bottom for rack-mount operation. Pin 2 is the data output, pin 3 is the positive DC voltage input, and pin 1 is ground. This XLR data output may be “split” with an XLR Y-cable to feed two VCX-80 units to give stereo 8-channel capability. Also, by installing factory customized firmware into the device ROM, the RD-8 slide faders can be assigned to any (or several) arbitrary VCX-80 channels. Contact a factory technical service representative for details.

## 8. Audio Connections and Cables

### 8.1 Balanced vs. Unbalanced Audio Connections

Balanced signal connections are preferred in pro audio applications because of their improved immunity to induced hum and noise. A properly shielded and wired balanced input stage on any product will by design reject most unwanted noise picked up by the cable as well as minimize ground loop problems. Therefore it is always advantageous to use balanced connections when running signal more than ten or fifteen feet, although particularly noisy environments (high RFI, EMI, etc.) may require that even short cabling be balanced. Ashly TRS (tip-ring-sleeve) balanced connections use the tip as (+) and the ring as (-) signal, with sleeve used for ground. Ashly XLR connectors use pin 2 (+) and pin 3 (-) with pin 1 ground.

Unbalanced connections are used mostly for short distance, high level signals (0dBu nominal). Most external EMI noise pick-up will be masked under the noise floor of the signal, assuming there is little or no gain following the unbalanced signal. If a gain stage does follow a signal, or if externally sourced noise persists, use balanced connectors.

The VCX-80 is factory configured for separate input and output 1/4 inch tip-ring-sleeve (TRS) jacks. Used this way, inputs and outputs can be wired balanced or unbalanced. An internally selected single jack TRS insert is also available (see section 8.4).

### 8.2 Input Connections

VCX-80 audio inputs are 20K ohm active balanced or 10K ohm unbalanced on 1/4 inch TRS jacks.

*Note: If the single jack TRS insert mode is selected (see section 8.4), the In jack serves as the TRS insert.*

### 8.3 Output Connections

The outputs are 200 ohm pseudo-balanced (balanced impedance but signal drive on tip only) on 1/4 TRS jacks.

*Note: If the single TRS insert jack mode is selected (see section 8.4), the output signal is taken from the ring of the In jack, while the Out jack is not used.*

**Input and Output Configuration Options:**

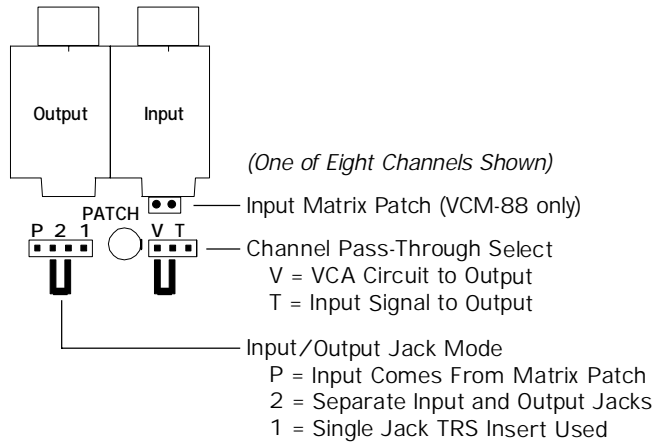

**8.4 Single Jack TRS Insert**

To use a mixing console's single jack insert capabilities with the VCX-80, an internal jumper must be selected to properly configure the input and output connections. The jumper must be placed in the "1" position (see drawing at top of page) for single jack in/out operation. With the jumper set to "1", the input is on the tip and the output is on the ring of the In jack. The Out jack is not used. This convention is compatible with most mixing consoles equipped with single TRS insert jacks, but check your mixer specifications before assuming this to be true.

**8.5 Master Output**

This 1/4 inch jack provides a 200 ohm pseudo-balanced output which is a summed mix of all eight channel outputs, useful for personal monitor mixes. Using individual channel outputs concurrent with the Master Output does not affect the Master Output in any way. The gain from any one input channel to Master Output is -6dB so that a mix of several audio channels will have approximately the same volume as one of the input channels.

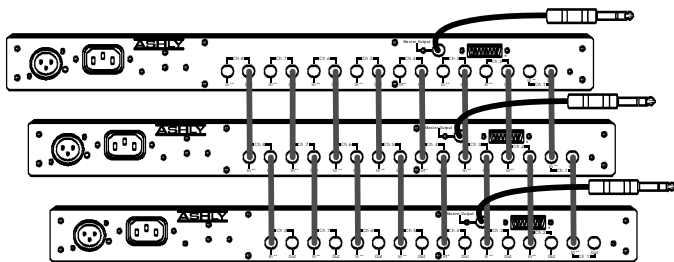

Using Master Outputs on Multiple VCX-80 Units. Channel Pass-Through is Used to Daisy-Chain Inputs.

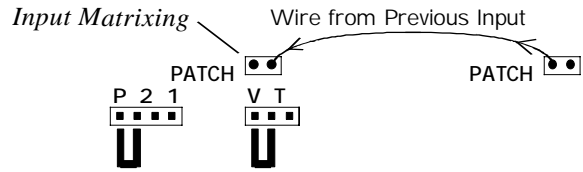
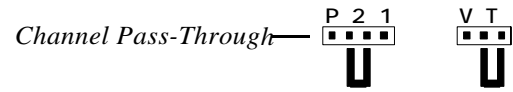
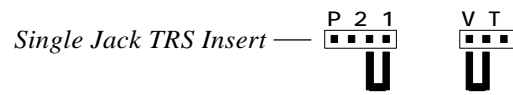

**8.6 Single Channel Pass-Through**

When Using Master Output for personal monitor mixing or other application, it is possible to pass a channel's input directly to its output jack, eliminating the need for extra "Y" cables when daisy-chaining several VCX-80 units together. Place the internal jumper in the "T" position (see drawing at top of page) to select individual channel pass-through. The VCA circuit's output signal is still summed to the Master Output, but is removed from the channel output jack.

**8.7 Input Matrixing (VCM-88 only)**

Input Matrixing allows for any channel's input to be internally patched into additional channel inputs for independent, multiple zone level control of a common audio signal.

There are two steps required for input matrixing. First, the internal jumper must be set to the "P" position (see drawing at top of page) for each channel being patched into. The actual input channel used to connect to the input source remains in either the "2" position if separate input and output jacks are used, or the "1" position if using single jack TRS insertion.

The second step is to insert 22 gauge solid insulated "bell wire" from the Patch socket of the actual input to the Patch socket of the channel being patched into. Strip 1/4" of insulation from each end after cutting to the appropriate length, and firmly press the bare wire end straight into either side of the Patch socket, avoiding any kinks or bends along the strip length. Daisy chain the Patch sockets, one into the next, until all shared input requirements are met. Those channels which have received the internal patch input should all be set to the "P" position, and the input jack on each of those channels cannot be used, since each patched channel's input is derived internally.

**9. Data Connections and Configurations**

### 9.1 Remote XLR Data Connection

The Female XLR jack on the rear of the VCX-80 accepts the digital control signal from the RD-8 or RW-8 remote controller. The data signal can be sent through one channel of a standard audio snake without affecting adjacent audio channels, but *do not use an isolation transformer in the data line.*

The details of the Ashly VCX-80 digital format are as follows: Pin 1 is ground, Pin 2 is used for the data input signal to the VCX-80, and Pin 3 is used as a +26VDC power supply signal for powering the RD-8 remote controller (*do not use pin 3 with 3rd party hardware such as AMX or Crestron.*)

A valid message consists of two bytes with 0-8ms of break between byte 1 and byte 2. Standard Ashly Firmware is as follows:

1 Byte = start bit + 9 data bits + stop bit  
(11 bits total)

(256 different Channel IDs,  
Channel level step size = 0.375dB)

Baud rate: 4800 bps  
Start bit: logical 0 (current on)  
Stop bit: logical 1 (current off)  
Data bits: 1-8 = Channel ID or Level  
            9 = logical 1 for Channel ID,  
            logical 0 for Channel level

Channel ID Character: (bit 9 = 1)  
hex 00 - hex FF = Channels 1 - 256

Channel Level Character: (bit 9 = 0)  
hex FF = full on = +20dB  
hex CA = unity gain = 0dB  
hex 00 = off = -75dB

### 9.2 AMX and Crestron

Both AMX and Crestron provide proprietary hardware which interfaces with the VCX-80 through the XLR Data In connector. To learn about their integrated control systems, visit their websites at <www.amx.com> and <www.crestron.com>.

AMX controls the VCX-80 without any changes to the VCX-80 factory settings. To use a Crestron control system, the data format jumpers in the VCX-80 must be selected to the Crestron position (see drawing at right). These jumpers are labeled on the printed circuit board as well.

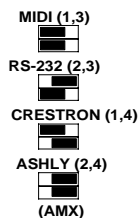

Data Jumpers on Circuit Board

### 9.3 DC Control Voltage Connection

The D-Sub 15 pin female connector offers direct DC voltage control of the internal VCA circuits, as well as the master level control. Direct DC control of the VCX-80 meets the remote control objectives with minimal hardware requirements and allows for custom "low-tech" hardware interfaces. Two wires are used to supply positive and negative DC voltage to ordinary 10K ohm linear-taper potentiometers, and a wire is used to return the wiper of each control to its respective channel (see pinout below). Telephone wire with eleven conductors or more is a good choice for this application, and since only DC voltage is used, control line distance is not a major concern.

- Pin 1 Channel 1 DC control input
- Pin 2 Channel 2 DC control input
- Pin 3 Channel 3 DC control input
- Pin 4 Channel 4 DC control input
- Pin 5 Channel 5 DC control input
- Pin 6 Channel 6 DC control input
- Pin 7 Channel 7 DC control input
- Pin 8 Channel 8 DC control input
- Pin 9 Master DC control input
- Pin 10 +15VDC - Connect to pot CCW
- Pin 11 (Ground for data input)
- Pin 12 -4VDC - Connect to pot CW
- Pin 13-15 Not Used

### 9.4 RS-232 Control and Protea System Software (VCM-88 only)

Protea System Software is Ashly's custom Windows program for controlling Protea graphic and parametric system processors, as well as the VCM-88. Using the software extends the capabilities of the VCM-88 by allowing storage of channel and scene settings to disk. The program interface has the look and feel of the RD-8 remote control, and can control up to 16 banks for a total of 128 audio channels. Protea System Software is available free of charge on the Ashly website <www.ashly.com>.

To use the VCM-88 with RS-232 control, the data jumpers must be placed in the RS-232 position on the printed circuit board, telling the microcontroller to expect RS-232 formatted data.

The RS-232 Input connector to a VCM-88 is a D-Sub 9 pin female, and connects to an unused Com port on a PC. Protea System Software allows Com Port assignment in its setup menu. Cable length for RS-232 should not exceed 50 feet.

9.5 MIDI Implementation (VCM-88 only)

The VCM-88 can be fully implemented in a MIDI system as a slave unit, that is, able to receive data without being able to generate new data. The MIDI Thru jack is a buffered reflection of the MIDI input, and is used to connect to other MIDI devices in the network. The quality and accuracy of MIDI control is limited only by the quality of the MIDI Master device.

To use the VCM-88 in a MIDI network, two circuit board jumpers must be placed in the MIDI position (see drawing on bottom of page 9), telling the microcontroller to expect MIDI formatted data.

Set the VCM-88 to the desired MIDI Channel (VCM-88 bank 1-16) using the Bank Select jumpers found on the circuit board (see drawing at right). Although 32 banks are possible with the VCM-88, only 16 banks can be addressed by MIDI. Bank 1 equals MIDI channel 1, bank 2 equals MIDI channels 2, and so on, up to bank 16.

VCM-88 MIDI Command Structure

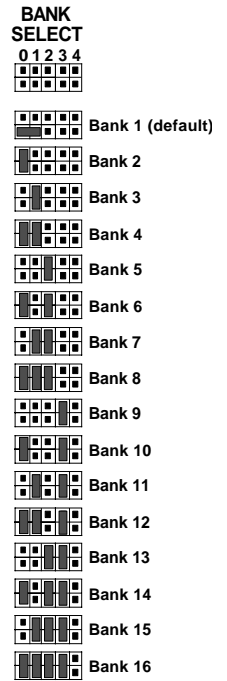
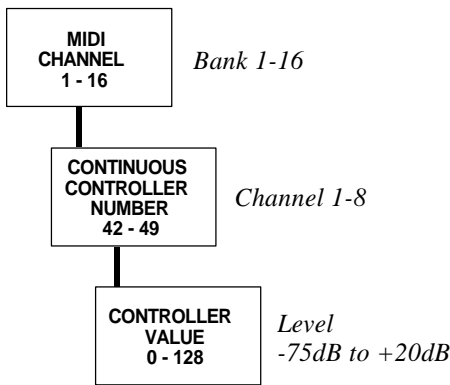

Each MIDI channel, or bank, has eight continuous controller numbers assigned for the eight audio channels in a VCM-88. On any given bank, controller number "42" is always channel 1, controller number "43" is always channel 2, and so on, up to controller number "49" for channel 8 of the VCM-88.

Each continuous controller number passes a controller value to the targeted channel to set the current audio level for that channel, and is updated every millisecond. The controller values range from "0" for -75dB, to "128" for +20dB, in approximately 0.74 dB increments. Unity gain has a controller value of "100".

If problems occur, be sure to check that the two jumpers are selected for MIDI, that the VCM-88 has been selected to the correct bank (MIDI Channel), that the correct continuous controller number is being used for the desired audio channel, and that the controller value is correct.

10. Troubleshooting Tips

10.1 No Output

Check AC power - is green power LED indicator on? Check input/output connections - are they reversed? Is the Master Attenuator control turned fully up? Are remote controller channels switched on? Are the input/output jacks configured correctly (one jack insert versus two jacks) for the application?

10.2 Very Little Output Signal

Are the yellow Limiter Threshold indicators on often? Rotate the recessed Threshold controls clockwise to allow greater output signals to pass unlimited. Check the Master Attenuator control - normally this control should be fully clockwise at 0dB. Check the RD-8 remote controller - the fader levels should normally be operated around 0dB.

10.3 Distorted Sound

The maximum input signal level is +23dBu = 10.95Vrms. Above this input level, input clipping distortion will occur. Also, if the input signal level plus the gain set by the remote controller goes above +23dBu, output clipping distortion will result.

10.4 Excessive Hum or Noise

Hum and buzz noise is usually caused by a "ground loop" between audio components. Try using balanced input and output connections between the VCX-80 and other components in the system. Also, try to power all components in the system from a single AC branch circuit.

Noise can also be caused by a large amount of gain applied to an insufficiently low input signal. *The VCX-80 and VCM-88 are not designed to feed microphones directly into the inputs without a mic preamp first.* The VCX-80 is essentially a line level unity-gain device, meaning it is designed to be fed by a nominal 0dBu line

level signal and its output should typically be 0dBu in level. To ensure proper gain structure in your sound system, press the remote disable switch in and rotate the Master Attenuator control fully clockwise so that all VCX-80 channels are at unity gain. Adjust your signal source which precedes the VCX-80 for nominal 0dBu signal levels, then push the Remote Disable switch out for remote controllability.

If you still have problems, contact your Ashly dealer or call Ashly direct at (800) 828-6308.

## 11. Warranty Information

We thank you for expression of confidence in Ashly products. The unit you have just purchased is protected by a limited five year warranty. To establish the warranty, you must first complete and mail the warranty card attached to your product.

Fill out the information below for your records.

Model Number \_\_\_\_\_

Serial Number \_\_\_\_\_

Dealer \_\_\_\_\_

Date of Purchase \_\_\_\_\_

Dealer's Address \_\_\_\_\_

\_\_\_\_\_

\_\_\_\_\_

Dealer's Phone \_\_\_\_\_

Salesperson \_\_\_\_\_

OTHER INFORMATION:

## 12. SPECIFICATIONS:

### 12.1 Input

Input Type: 1/4" tip-ring-sleeve  
 Input Impedance:  
 20K ohm balanced, 10K ohm unbalanced  
 Max input level: +23dBu  
 Input jack may be internally selected  
 as a single in/out insert

### 12.2 Channel Outputs

Output Type: 1/4" tip-ring-sleeve  
 Output Impedance: 200 ohm pseudo-balanced,  
 100 ohm unbalanced  
 Max output level: +22dBu

### 12.3 Master Output

Output Type: 1/4" tip-ring-sleeve  
 Output Impedance: 200 ohm pseudo-balanced,  
 100 ohm unbalanced  
 Max output level: +22dBu

### 12.4 Audio Performance

Nominal Gain: 0dB +/-0.5dB  
 Gain Range: +20dB to -75dB  
 Frequency Response: +/-0.2dB 20Hz-20KHz  
 THD: <0.01% at 0dBu and 1KHz  
 <0.15% at +20dBu, 20Hz-20KHz  
 Output Hum & Noise:  
 <-94dBu 20Hz-20KHz unweighted  
 Crosstalk: <-80dB at 20KHz

### 12.5 Signal Present (*VCM-88 only*)

Green LED turns on at -17dBu

### 12.6 Limiter

Threshold Range: -23dBu to +22dBu  
 Compression Ratio: 10:1

### 12.7 Data Input

Input Type: XLR jack  
 pin 2=data, pin 3=+V, pin 1=ground  
 Data Format: 2Vp raised-cosine,

### 12.8 RS-232 Input (*VCM-88 only*)

Input Type: D-Sub 9 pin female  
 pin 3=data, pin 5=ground  
 1 start, 9 data, 1 stop bits at 4800 baud

### 12.9 DC Control Inputs

Input Type: DB 15-pin female connector  
 Control Voltage: -4V to +15V provided for  
 external 10K ohm potentiometers

### 12.10 Overall

Size: 19"L x 1.75"H x 6"D  
 Power Requirements: 98-125VAC, 50-60Hz  
 18W (240V available)  
 Shipping weight: 9 lbs.

### 12.11 RD-8, RW-8 Specifications

Fader Range: +10dB to -75dB  
 (master fader at 0dB)  
 Data/Power Connector: Male XLR jack  
 Max Data Cable Length:  
 1500 ft. of 24 ga. twisted pair  
 Data Format: 4800 baud, 2Vp raised cosine  
 Data crosstalk to audio:  
 <-120 dB along 1000' of 150 ohm shielded cable

Size: 7.5"L x 3.5"H x 1.75"D  
 Power Requirements:  
 Phantom powered by VCX-80  
 Shipping Weight: 3 lbs.

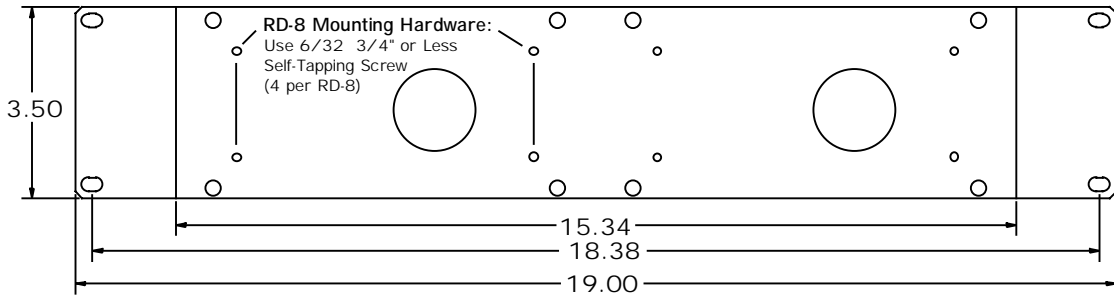
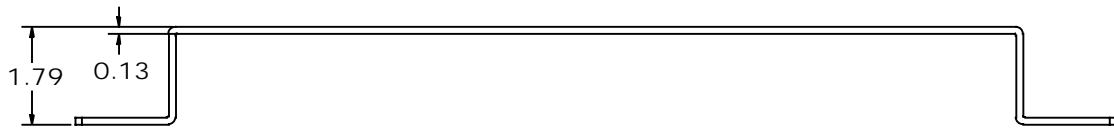
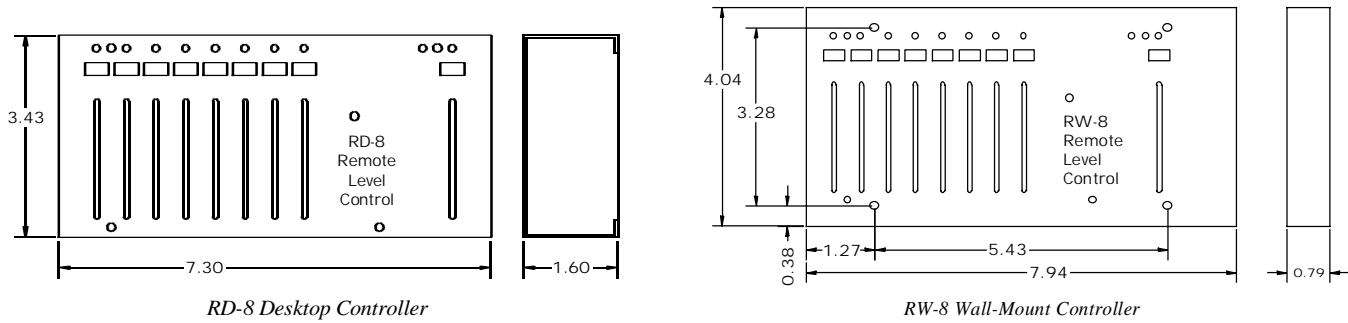

Rack-Mounting Kit For One Or Two RD-8 Remote Controllers

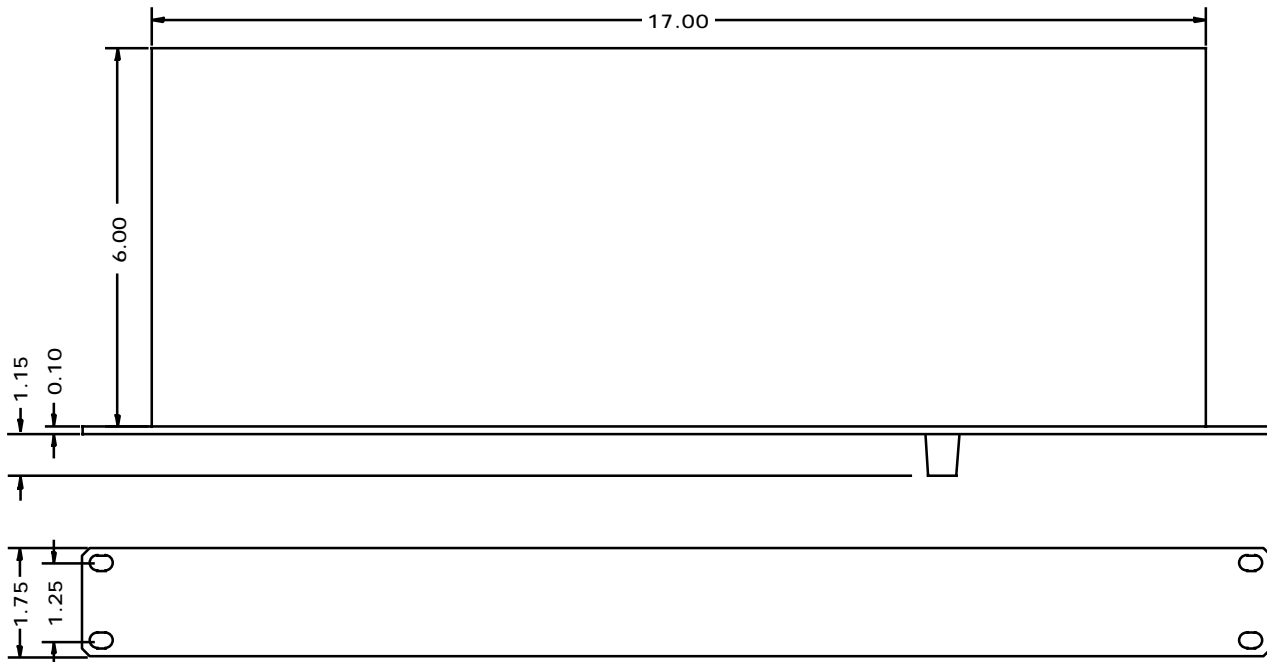

Dimensional Drawing for VCX-80 and VCM-88



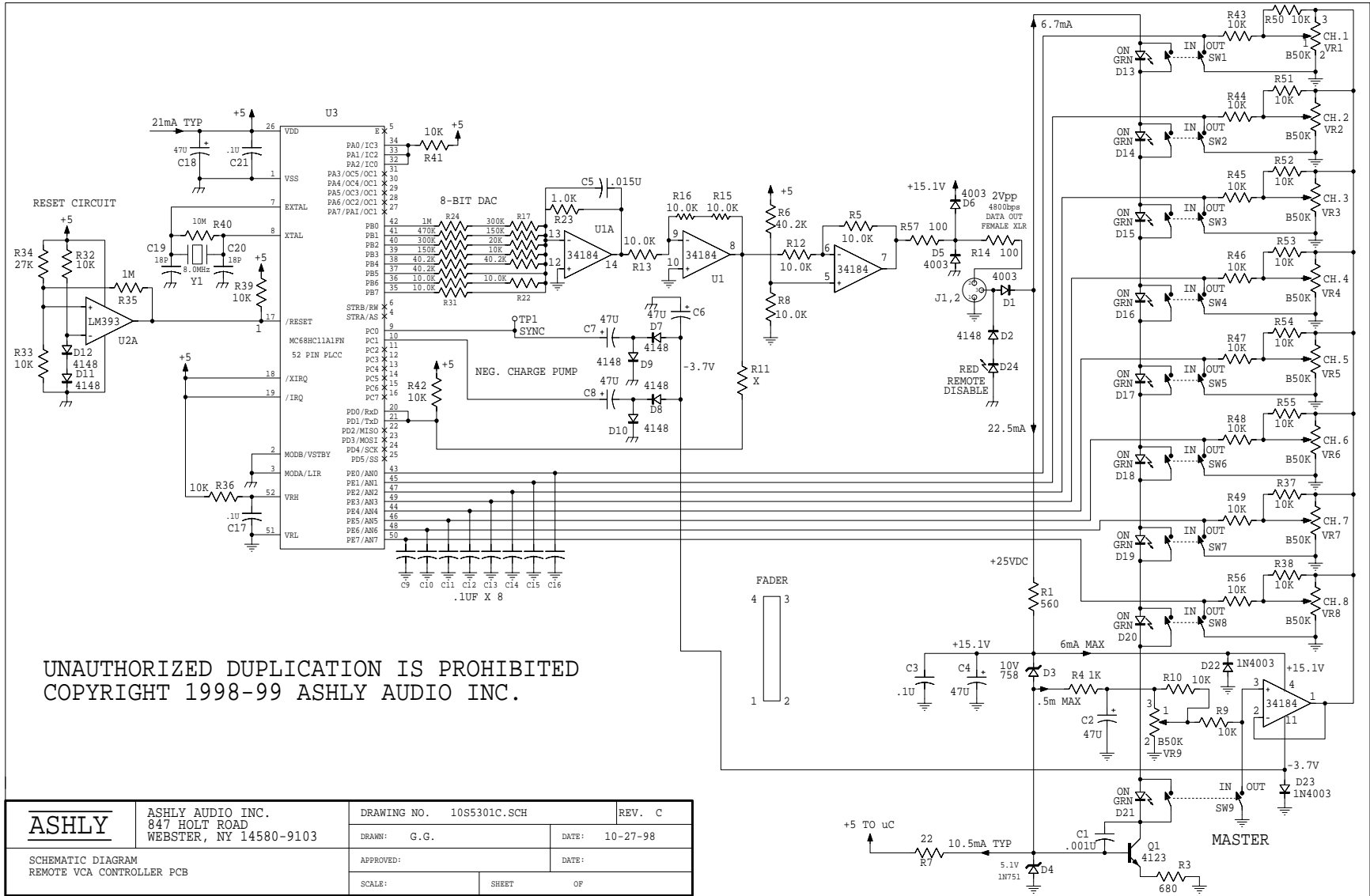

Figure 14.1: RD-8/RW-8 Remote Control Schematic Diagram

## Common Applications

- **Eight In, Eight Out Individual Channel Remote Control**

*Use for individual mixer channel or subgroup remote control, especially suited for situations where the audio equipment rack is installed away from an adequate listening point. Also useful to control monitor levels/mixes from the front-of-house position. Separate input/output jacks or single jack TRS patch available. Control with RD-8, RW-8, Custom DC Voltage Controller, and AMX or Crestron Touch Screen Systems. VCM-88 allows MIDI, RS-232, or Protea System Software control as well.*

- **Eight In, One Out For Remote Control Sub-Mixing**

*Use up to eight inputs and the Master Output to allow mixdown of all VCX-80 inputs. Individual channel pass through is available to daisy-chain multiple VCX-80 units together for personal monitor mixes. Control with RD-8, RW-8, Custom DC Voltage Controller, and AMX or Crestron Touch Screen Systems. VCM-88 allows MIDI, RS-232, or Protea System Software control as well.*

- **One In, Eight Out For Remote Control of Distributed Zones**

*Use Input Channel Patch (VCM-88 only) to internally jump one channel's input into one or more other inputs for distribution of single audio signal. Control with RD-8, RW-8, Custom DC Voltage Controller, and AMX or Crestron Touch Screen Systems. VCM-88 allows MIDI, RS-232, or Protea System Software control as well.*

- **Limiter With Threshold Control On All Eight Channels**

*Use VCX-80 as stand-alone eight channel, true VCA peak limiter, with adjustable threshold on each channel. No controller is required.*

**ASHLY**

ASHLY AUDIO INC. 847 Holt Road Webster, NY 14580-9103

Phone: (716) 872-0010 Fax: (716) 872-0739

Toll Free (800) 828-6308 Internet: [www.ashly.com](http://www.ashly.com)

© 1999 by Ashly Audio Corporation. All rights reserved worldwide.