

# RD-8C, RW-8C Remote Level Control

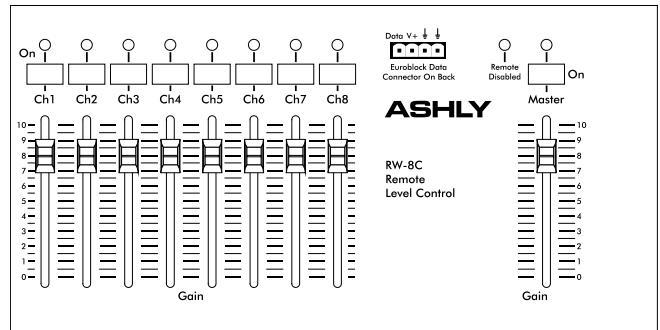

**Introduction:** The RD-8C and RW-8C are remote level controllers which can be used with the Ashly VCM-88C, as well as ethernet based Ashly NE signal processors, NE power amplifiers with DSP capabilities, and Pema amplifiers. The RD-8C is a desktop controller using an XLR data connector, while the RW-8C is electronically the same but mounts as a wall plate into a standard 4-gang electrical box and uses a euroblock connector. There are eight channel faders and one master fader on the RD-8C, each with a level control and an on/off button with a green LED to indicate status.

**Used with the VCM-88C,** the RD/RW-8C offers a direct correlation of remote faders to VCM-88C channels, as well as its master fader. Connect the RD-8C or RW-8C to a VCM-88C as illustrated above.

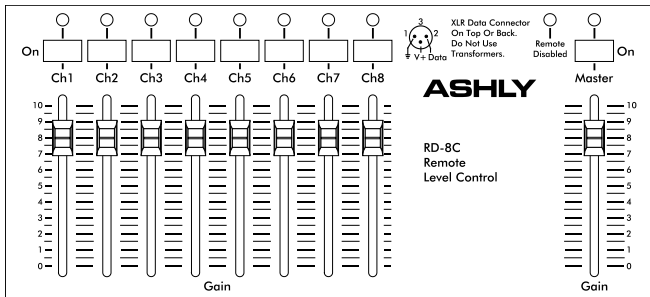
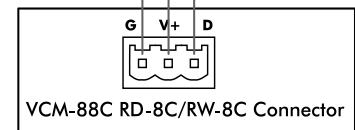
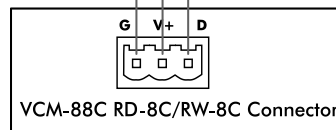
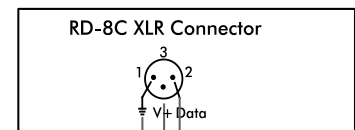
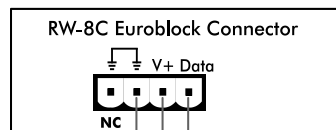

Channel 1 on a RD/RW-8C will always control channel 1 on the VCM-88C, and likewise channels 2-8 and the master will each control their respective VCM-88C channel. The data output signal may be “split” in order to feed two VCM-88C units to give stereo 8-channel capability. A Remote Disabled LED indicates when the RD/RW-8C has been disabled by the VCM-88C front panel switch. This LED is inactive when the RD-8C is used with NE products.

**Used with Ashly NE products,** assuming they have DSP capabilities, each RD/RW-8C slide fader can be assigned in Protea NE Software as a remote level control tool for one or several inputs or outputs. *Only one RD/RW-8C can be used per NE device, and no other serial communications devices, including the WR-5, can be used when an RD-8C is connected to the data port.* Connect the RD-8C or RW-8C to NE products as illustrated above.

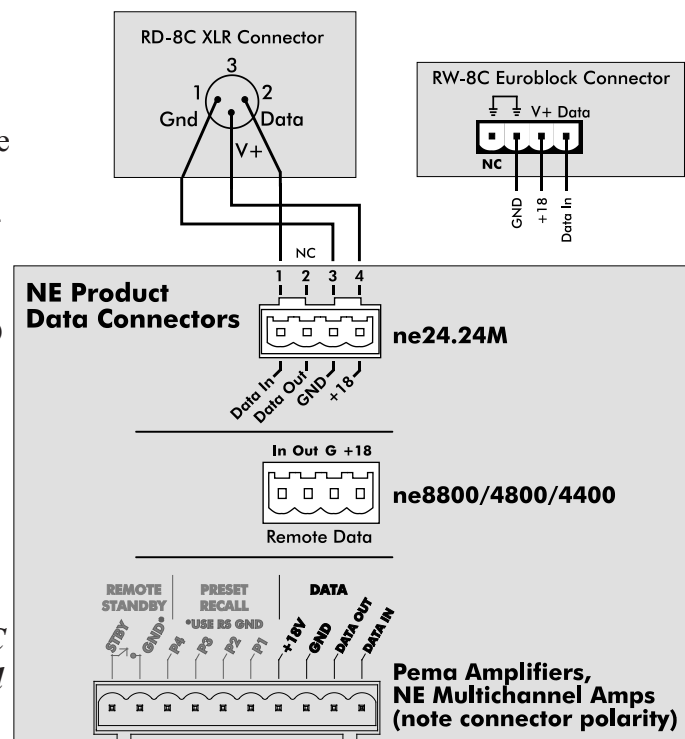

In the Protea NE software window, the RD-8C will appear in an expanded menu tree along with its host unit in the left side listing of the screen. An offline or disconnected host unit will appear in red text while an online unit appears in green. Individual NE products and their remote control units can be dragged onto the project canvas to simulate physical rack and room installation groups, but editing each product can be done from either the product list or the canvas. Once an image has been placed on the canvas, it must be manually deleted (right click-delete) if that device is no longer available to the software. Scanning for devices does not automatically remove images or list items which may have been installed at one time but are now off line.

The project canvas is used to visually represent and control a fixed physical sound system installation, and can display all Ashly NE processors, amplifiers, and remotes used in that system. Lines, rectangles, text, and image files can be added to create a custom virtual control screen along with the NE products and individual control objects. To see all available canvas tools, right click anywhere over open canvas. Checking <Design Mode> allows placed objects to be moved around, while unchecking <Design Mode> locks objects in place.

<b>Specifications:</b>	<b>RD-8C</b>	<b>RW-8C</b>
Fader Range:	.....+10dB to -75dB	+10dB to -75dB
Connections:	.....XLR Male	Two-piece Euroblock
Max Data Cable Length:		
With VCM-88C	.....up to 1000 ft using #24 gauge twisted pair	
With NE products:	.....up to 1000 ft using #24 gauge twisted pair	
Power Requirements:	.....phantom powered	phantom powered
Shipping Weight:	.....3 lbs (1.4kg)	3 lbs (1.4kg)
Dimensions:	.....7.3"(185mm)L	7.94"(202mm)L
	3.4(87)H	4.0(103)H
	1.6(41)D	0.8(20)D
Environmental:	.....40-120 deg. F	40-120 deg. F
(non-condensing)	(4-49 deg. C)	(4-49 deg. C)

**Ashly Audio Inc. LIMITED WARRANTY (USA ONLY)**  
**(Other countries please contact your respective distributor or dealer.)**

**For units purchased in the USA**, warranty service for this unit shall be provided by ASHLY AUDIO, INC. in accordance with the following warranty statement.

ASHLY AUDIO, INC. warrants to the owner of this product that it will be free from defects in workmanship and materials for a period of FIVE years from the original-date-of-purchase. ASHLY AUDIO INC. will without charge, repair or replace at its discretion, any defective product or component parts upon prepaid delivery of the product to the ASHLY AUDIO, INC. factory service department, accompanied with a proof of original-date-of-purchase in the form of a valid sales receipt. This warranty gives you specific legal rights, and you may also have other rights, which vary from state to state.

**EXCLUSIONS:** This warranty does not apply in the event of misuse, neglect, or as a result of unauthorized alterations or repairs made to the product. This warranty is void if the serial number is altered, defaced, or removed. ASHLY AUDIO, INC. reserves the right to make changes in design, or make additions to, or improvements upon, this product without any obligation to install the same on products previously manufactured.

Any implied warranties, which may arise under the operation of state law, shall be effective only for FIVE years from the original-date-of-purchase of the product. ASHLY AUDIO, INC. shall be obligated to only correct defects in the product itself. ASHLY AUDIO, INC. is not liable for any damage or injury, which may result from, or be incidental to, or a consequence of, such defects. Some states do not allow limitations on how long an implied warranty lasts, or the exclusion, or limitation of incidental or consequential damages, so the above limitations or exclusions may not apply to you.

**OBTAINING WARRANTY SERVICE:**

For warranty service in the United States, please follow this procedure:

1) Return the product to ASHLY AUDIO, INC. freight prepaid, with a written statement describing the defect and application that the product is used in. ASHLY AUDIO, INC. will examine the product and perform any necessary service, including replacement of defective parts, at no further cost to you.

2) Ship your product to:

ASHLY AUDIO, INC.  
 Attention: Service Department  
 847 Holt Road

Webster, NY 14580-9103

**Ashly Audio Inc 847 Holt Rd Webster NY 14580**  
**585-872-0010 toll free 800-828-6308 fax 585-872-0739 www.ashly.com**

© 2011 by Ashly Audio Corporation. All rights reserved worldwide. RD-8, RW-8 R-3 01-11

