



ne 8800

ne 4800

ne 4400

**Network Enabled
DSP Processor**

ASHLY AUDIO INC.

847 Holt Road Webster, NY 14580-9103 Phone: (585) 872-0010

Toll-Free: (800) 828-6308 Fax: (585) 872-0739 www.ashly.com

Table Of Contents

1 INTRODUCTION	3
2 UNPACKING	3
3 THE NE PROCESSOR SERIES	3
4 AC POWER AND MECHANICAL REQUIREMENTS	4
5 GETTING STARTED	4
6 FRONT PANEL FEATURES	5
7 STANDARD BACK PANEL FEATURES	6
8 OPTIONAL FEATURES	7
8.1 Mic Input Channels	7
8.2 AES/EBU Input Channels	7
8.3 AES/EBU Outputs	7
8.4 Network Audio	7
9 PROTEA NE SOFTWARE	8
9.1 Device Options	8
9.2 Preset Options	9
9.3 NE Processor Control Surface	9
10 REMOTE CONTROL	10
10.1 WR-5 Programmable Zone Controller (Remote Data)	10
10.2 RD-8C or RW-8C Remote Control	11
10.3 WR-1 5VDC Remote Volume Control	11
11 SPECIFICATIONS	12
12 TROUBLESHOOTING TIPS	14
13 WARRANTY INFORMATION	16

1. INTRODUCTION

Thank you for your purchase of this NE (network enabled) processor. The ne8800, ne4800, and ne4400 combine state of the art DSP processing with Ethernet control, and use optional factory installed expansion cards to provide mic inputs, comprehensive AES/EBU digital audio input/output, as well as full integration with network audio systems such as CobraNet or EtherSound. Please read the entire manual to fully understand the features and capabilities of this product.

About Ashly

Ashly Audio was founded in 1974 by a group of recording engineers, concert sound professionals, and electronics designers. The first products were elaborate custom consoles for friends and associates, but business quickly spread to new clients and the business grew. The philosophy we established from the very beginning holds true today: to offer only the highest quality audio tools at an affordable cost to the professional user – ensuring reliability and long life. More than thirty years later, Ashly remains committed to these principles.

Ashly's exclusive Five Year, Worry-Free Warranty remains one of the most liberal policies available on any commercial-grade product. The warranty covers every product with the Ashly brand name, and is offered at no extra cost to you, our customer.

FCC Compliance

This device complies with part 15 of the FCC Rules. Operation is subject to the following two conditions:

1. This device may not cause harmful interference
2. This device must accept any interference received, including interference that may cause undesired operation.

2. UNPACKING

As a part of our system of quality control, every Ashly product is carefully inspected before leaving the factory to ensure flawless appearance. After unpacking, please inspect for any physical damage. Save the shipping carton and all packing materials, as they were carefully designed to reduce to minimum the possibility of transportation damage should the unit again require packing and shipping. In the event that damage has occurred, immediately notify your dealer so that a written claim to cover the damages can be initiated.

The right to any claim against a public carrier can be forfeited if the carrier is not notified promptly and if the shipping carton and packing materials are not available for inspection by the carrier. Save all packing materials until the claim has been settled.

3. THE NE PROCESSOR SERIES

There are three processor models, each with line level inputs and outputs, a full suite of DSP processing functions per channel, 10/100 EtherNet control, eight assignable 12V Digital Logic I/O ports, eight DC level control ports assignable to input or output levels, a RS-232 control port, and a remote data port for programmable controllers such as the Ashly WR-5 and RD-8C.

Base Models:

ne4400 - Four line inputs, four line outputs

ne4800 - Four line inputs, eight line outputs

ne8800 - Eight line inputs, eight line outputs

In addition to the base model features, models can be custom ordered with various combinations of mic preamp inputs, AES/EBU inputs and outputs, and CobraNet or Ethersound network audio cards.

4. AC POWER AND MECHANICAL REQUIREMENTS

The NE Processor uses a universal power supply rated for operation from 100VAC to 240VAC, and requires a properly grounded AC connection. The unit mounts to a standard 19 inch equipment rack. A cooling fan draws air in from the right side and blows air out the left side when viewed from the front.

5. GETTING STARTED

Load the software

Ashly Protea NE software is included on a CD with each unit. Check the Ashly web site at www.ashly.com to verify that you are installing the latest software release. Autorun will launch the application <ProteaSystemSoftwareNE> to install the Protea software. A note about firewalls: When running Protea NE software on a PC for the first time, Windows will prompt the user to allow the software through any active firewalls. Allow this. Once the software is properly installed, Windows must be configured to permanently allow a firewall exemption for Protea NE software.

Connect to Ethernet

The Ethernet control connection is made using an RJ-45 terminated eight conductor cable connected directly to a computer or indirectly over a standard 10/100M Ethernet network. Maximum cable distance for Ethernet is 100 meters from the nearest hub or switch for copper twisted pair CAT5 cable. For more detailed information about the proper implementation of an ethernet network, review one of the many comprehensive Ethernet networking guides available on the internet.

Identify the processor in software

Once the software is loaded to the computer and an Ethernet connection has been made to the NE processor, all Ashly NE products installed on that network will be automatically detected and shown in the active device listing on the left side of the Protea software startup canvas. In addition to detecting which models are currently online, any factory installed options (mic preamps, AES/EBU, CobraNet, Ethersound) are also detected and the software control surface for the new NE product automatically displays available controls for the options present. *Note: In the event of multiple processors of the same model on the network, the user can find a single physical unit by right clicking over the unit's name in the drop down menu or picture on the canvas, and then click <Identify>, which will flash the Com LED on that unit's face panel for two seconds.*

The software scans for active NE devices on power-up, but the user can manually scan at any time as well with <Scan For Devices> at the bottom of the network NE device listing. Also, all NE devices continuously broadcast their availability to the software. All currently connected and active NE products are highlighted in green, while NE products which may be or have been formerly installed but are currently off-line or unavailable show up in red. Individual NE products can be dragged onto the project canvas to simulate physical rack installation groups, but editing each product can be done from either the product list or the canvas.

The NE system project canvas

The project canvas is used to visually represent and control a fixed physical sound system installation, and can display any of the Ashly NE processors, amplifiers, and remotes used in that system. The user can also place an assortment of isolated control objects such as level faders, single LEDs, meter bars, etc, and map them to specific product functions within that project. Once a control object is placed, right click on it to bring up its properties. Lines, rectangles, text, even image files can be added to create a custom virtual control screen along with the NE products and individual control objects. To see all available canvas tools, right click anywhere over open canvas. Checking <Design Mode> allows placed objects to be moved around, while unchecking <Design Mode> locks objects in place.

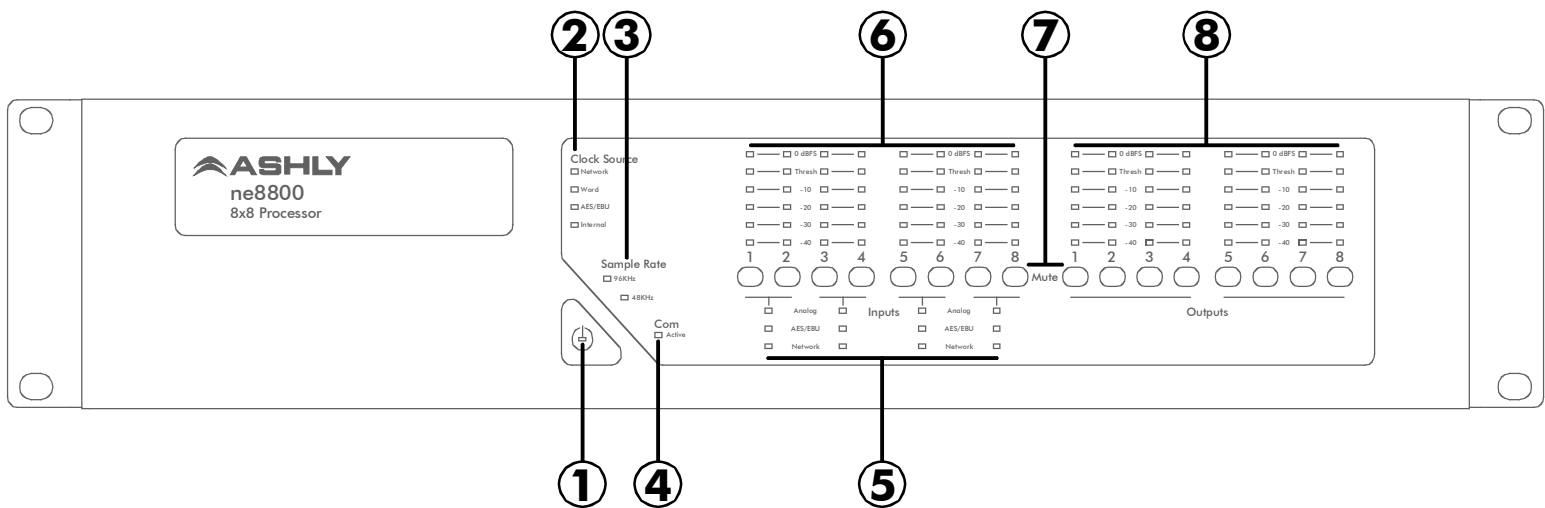

6. FRONT PANEL FEATURES

1. Power LED – Indicates the unit is turned on.

2. Clock Source – The Network clock, Word clock, AES/EBU clock, or Internal clock are indicated according to the master clock source selected in the control software. The Network clock LED turns orange to indicate Net Matrix Mode.

3. Sample Rate – A 48KHz or 96KHz sampling rate can be selected from within software. A second function is also indicated here when the firmware is reprogrammed with an updated file, as both sampling rate LEDs will light up for the duration of the file transfer (about two minutes).

4. Com LED – The Com LED indicates that data is being sent or received via the Ethernet control port. The Com LED can also be made to flash on for two seconds to visually identify a physical unit from within the software.

5. Input Source – If more than one type of input is available for a given channel pair, an input source selection tab is available in software. Here the user can select an input pair source as analog (line input), analog (mic preamp), AES/EBU input, network audio, as well as set the input source selection to auto detect digital audio sources while automatically switching back to analog input when no AES/EBU or network audio signals are present. Green LED color = “Selected”, Red = “Not Valid”, and Off = “Not Being Used”.

6. Input Level Meters – Input LED level meters reference the actual signal level at the A/D converter *prior* to the DSP section. Levels displayed on the front panel are measured in dBFS (Decibels Full Scale), where 0dBFS is the maximum level possible, thus are also true clipping indicators. The Threshold LED is used for dynamics functions configured in the DSP Controls section of the software.

7. Input/Output Mute– This button is pressed to mute the input or output channel, and will additionally update that channel’s mute status as shown in software. Green means the channel is unmuted, while red means the channel is muted and will not pass audio. For security, all front panel mute controls can be disabled from within software under <Device Options>, then <Disable Front Panel Mutes>. If a mic input channel is set up for the push to talk function using logic I/O pins, that channel’s mute button will illuminate orange to indicate its push to talk status, and turn green whenever the mic button is pressed.

8. Output Level Meters – Like the input meters, output meters reference 0dBFS, meaning 0dBFS is the true clipping point, and are measured from the D/A converter point following the DSP section.

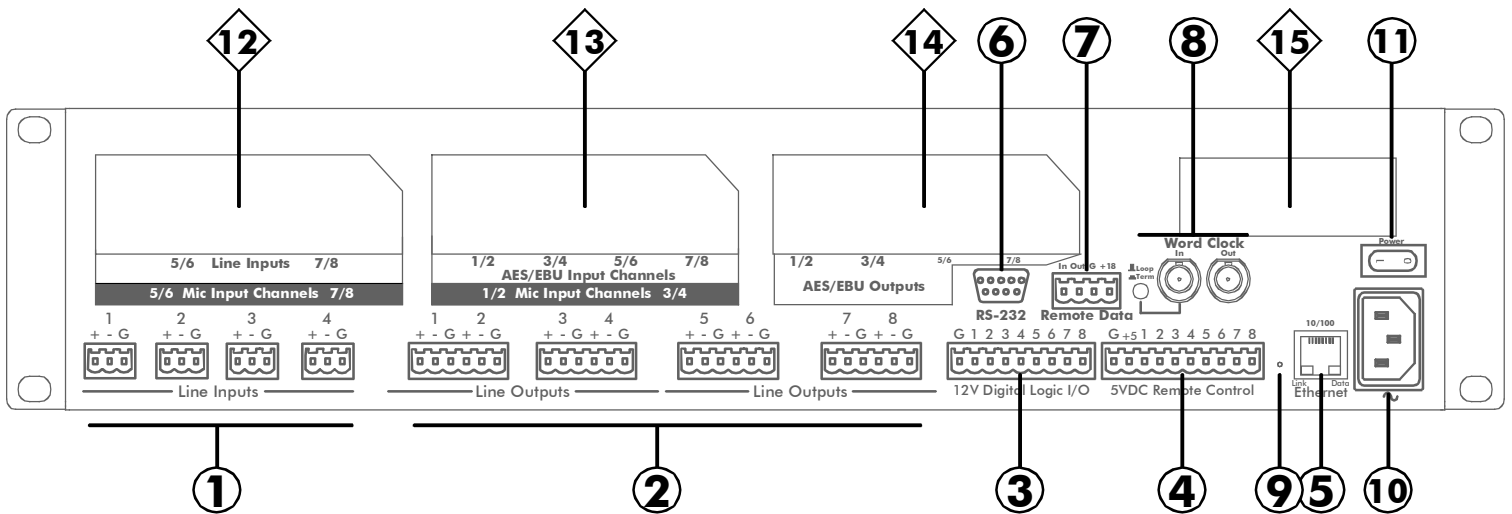

7 STANDARD BACK PANEL FEATURES

1. Line Inputs – Depending on the model, there are either four or eight line inputs available on the NE processor. Line inputs are active balanced with euroblock connectors, and if an unbalanced signal is used, be sure to ground the unused path. Maximum input level is +20dBu = FS (full scale).

2. Line Outputs - Depending on the model, there are either four or eight line outputs available. Line outputs are servo-balanced with euroblock connectors, and may be wire balanced or unbalanced, with a maximum output level of +20dBu FS.

3. 12V Digital Logic I/O - All models have a nine pin euroblock connector for logic inputs or outputs. The Logic I/O tab in software allows logic pins to be assigned as either logic inputs for contact closure preset recall, mic push to talk function, or as current-limited 12V logic outputs for control of 12V or 5V external devices.

4. 5VDC Remote Control - All models have a 10 pin euroblock connector for accomodating up to eight user defined remote DC level controls. This is done by using an Ashly WR-1 remote attenuator (or equivalent 10K linear potentiometer) along with a remote gain block placed within the DSP section, so that each of the eight Remote DC level control pins can be assigned to any channel's input or output section. Wire the 5VDC Remote Control ground to the CCW pin of the remote control potentiometer, wire +5 to the CW pin, and wire the control pin (1-8) to the potentiometer wiper.

5. Ethernet Jack - This is the 8P8C (RJ-45) connector used for 10/100 ethernet control. Maximum cable distance to the nearest computer, hub, or switch using CAT5 twisted pair copper cable is 100 meters.

6. RS-232 Jack - This connector is for remote control by non-Ethernet based hardware (older Crestron, AMX, etc) which may use RS-232 control data protocol.

7. Remote Data - This is used to connect a WR-5 programmable remote control or a RD-8C remote level control.

8. Word Clock - If two pieces of digital audio gear need to be synchronized, i.e. their sample rates are very slightly different and must be made to match exactly, word clock synchronization is necessary to avoid sample skipping. Additionally, when several pieces of gear are cascaded in an AES/EBU digital audio chain, each digital audio input adds some small amount of clocking jitter and perhaps sample delay. After several units, the cumulative jitter could cause a loss of lock (and hence loss of audio), increased distortion due to large amounts of jitter, or even a small delay. By connecting a master word clock to each device, they all become precisely synchronized.

The NE processor defaults to “Auto Selection” which automatically detects a Network, Word Clock, AES/EBU, or Internal master clock source and automatically switches, in this order of priority. Therefore, in most system configurations, the user doesn’t need to worry about the master clock source, the processor will automatically pick the best master clock from the highest priority available. The processor will mute all audio outputs for about one second when it switches master clock sources. This Auto Selection mode can be over-ridden in the control software by clicking on <Device Options, Sample Rate & Master Clock Selection>.

The word clock switch on Ashly equipment provides two functions. First, it routes the word clock input signal hard-wired looped-through to the word clock output jack when in the OUT (Loop) position, but breaks the signal and generates an internal word clock source in the IN (Term) position. Secondly, the OUT position does not apply any load to the looped-through word clock signal, but the IN position applies a 75 ohm termination to the word clock input and supplies a 75 ohm source impedance to the word clock output. Therefore, the word clock switch should be in the IN “term” position whenever the unit is at either *end* of the word clock line, and in the OUT “loop” position when placed anywhere else along the line. No external terminations are needed.

9. Factory Reset - To reset the NE processor to original factory settings and permanently erase all stored preset data from the unit, use a paper clip or similar object to depress the recessed switch and hold for six seconds during power up. Factory reset is complete when all channel LEDs on the face panel are lit.

10. AC Inlet - 100-240 VAC, 50-60Hz AC cord. **Do not remove or lift the mains connector ground.**

11. Power Switch - This switch applies and removes power to the unit.

8 OPTIONAL FEATURES

12. Mic Input Channels - High performance mic inputs are available as factory installed options for channels 1-4, and/or 5-8. Mic input connections are balanced euroblock, with switchable +48V phantom power. When a mic preamp option is installed, the <Input Source> tab appears in the software and represents the mic preamps as available input sources with an icon labelled <Pre>. Mic preamp gain of 0dB, +20dB, +40dB, or +60dB is set in the input source menu by clicking on the preamp icon for a given channel and checking the appropriate gain.

Some microphones in paging applications have a button/switch which the user must push in order to use the microphone. This button acts as a contact closure which is wired to a logic input and used to control mute and ducking functionality. When the <Push To Talk Mic> box is checked in the input preamp section, that channel’s mic will only be unmuted when the assigned logic pin’s contact is closed (the button is pressed). *Note: the push to talk mic feature mutes the mic channel and indicates its status by turning the mute button orange.* Manual mute will still override the push-to-talk unmuting of that channel. Also, if that mic is also a ducking trigger, it will trigger the ducked channel level reduction immediately, regardless of the mic input level.

13. AES/EBU Input Channels - AES/EBU is a digital audio format where two channels of digital audio are transmitted over one standard mic cable. If installed, the AES/EBU input expansion card with four inputs can receive up to eight channels of audio which can then be routed, processed, and distributed. When an AES/EBU input is installed, the input source select tab allows for exclusive selection of AES/EBU input, as well as selection of AES/EBU with analog backup in the event there is no digital input signal. AES/EBU has a cable length limitation of about 100 meters depending on cable type and impedance ratings. Refer to the AES/EBU specifications for detailed line impedance and impedance matching information.

14. AES/EBU Outputs - AES/EBU outputs, if installed, always carry the exact same audio signals as the line outputs, except in AES/EBU format. There is no access to AES/EBU outputs in software.

15. Network Audio Card - Ashly currently supports two network audio formats, CobraNet (www.cirrus.com), or EtherSound (www.ethersound.com). With either network audio card installed, the NE processor acts as a full featured audio interface portal into or out of the larger audio network. See the NE software section on network audio for further implementation details.

9. PROTEA NE SOFTWARE

Device Options

Flash Reprogram

The NE processor firmware (the internal program that runs the unit) can be updated/reprogrammed via the Ethernet control connection. The new firmware file must be obtained directly from Ashly or through our web site, and installed according to the <Flash Programmer> dialogue box. This process may take several minutes, and during the file transfer all channels are muted and both sampling rate LEDs will be lit.

Link Configuration

Linking allows multiple DSP processing blocks on different channels or even different Ashly NE devices to track each other. For example - if two graphic equalizers on different channels are linked, any change made to one of the equalizers will result in an identical change to the other. Most DSP blocks can be linked to one of eight link groups. When a DSP function is assigned to a link group, both a colored tab *and* the link group number appear beneath the DSP block icon. The link group's tab color, group name, and local/network (link across devices) status is assigned in the link configuration dialogue box. *Note: If a WR-5 or RD-8C is connected to a NE device, and a DSP function that can be controlled by the WR-5 or RD-8C (such as gain) is linked across multiple devices, changes made by that WR-5 or RD-8C will only affect the host NE device. Linked changes across devices must come from the NE software, not remotes.*

Meter Display

Meter displays that are in the software for this NE processor can be set to a VU, dBu, or dBFS (dB Full Scale). dBFS is typically used when all or most of the gain/level adjustments occur in the DSP domain. The front panel LEDs on the NE processor are labelled dBFS. For comparison, 0 dBFS is the same as +20dBu on a product which clips at +20dBu. Therefore, -20dBFS is typically the desired operating range, while still allowing 20dB headroom for transient signals.

AES/EBU Receiver Status

With the AES/EBU input option installed, each of the four stereo AES/EBU inputs can be monitored for detected sample rate and other data errors that may occur between the AES/EBU source and the NE processor input. This can be useful for diagnosing problems in either communication setup or wiring. Any errors detected by the NE processor are latched, meaning even an intermittent error will be detected and remain highlighted until the <Reset Errors> button is clicked.

Sample Rate and Master Clock Selection

This screen displays the current master clock source, current sample rate, and word clock status. Click on <Show Advanced Control> to change master clock or sampling rate. The factory defaults are auto selection of the master clock and 48kHz sampling rate. Note: Network audio may not necessarily run at 96kHz. Also, network audio has the highest master clock priority, because most network audio formats are unable to synchronize to a word clock master.

Disable Front Panel Mutes

This control prevents the NE processor mute buttons from functioning. Mute status can still be controlled from software.

DVCA Control

One of the DSP Gain block functions is called <Gain w/VCA>. With this function a channel can be assigned to one of four virtual subgroups, each with a master fader within software.

DSP Enable/Disable Control

The user can disable DSP functions on selected inputs, outputs, or the entire mixer to free up DSP processing power.

Network Audio Matrix

The network matrix input/output functions allow the NE processor to be integrated into a larger digital audio network. With a CobraNet or EtherSound network audio card installed, the NE processor can route incoming line, mic, or AES/EBU signals, including complete DSP processing of those signals, out to the external audio network. Likewise, individual channels off of the audio network can be chosen and routed (through DSP) to the analog or AES/EBU outputs of the NE processor.

Preset Options

Presets and Sub Presets

The NE processor will store up to 31 total presets or sub presets. A preset file takes a “snapshot” of all current settings and stores complete control data for all channels and all audio functions, while a sub preset, although in the same format as the full preset file, scans for and only stores the DSP parameters individually tagged as sub presets within each DSP tool box, within one channel or across multiple channels. Sub Presets are thus used to change only the selected functions. When naming presets or sub presets, indicate in the preset name if it is a sub preset, this will help later when assigning the sub preset to a recall event such as contact closure or WR-5 control. Individual presets (or sub presets) can be saved to the processor by using <Preset Options/Save Preset (Sub Preset) To Protea>, or saved to a PC using <Preset Options/Save (Sub Preset) To Disk>. Preset and sub preset files for Ashly NE products both use the extension (*.pne). A sub preset report can be generated to see what specific actions will be taken when loading a sub preset.

A preset or sub preset file can be recalled to a NE processor from either a computer or from the processor’s internal memory. An installation can be set up so that an Ashly WR-5 active programmable remote, or a contact closure, triggers the recall of presets or sub presets stored in the NE processor. For contact closure preset recall management, use the I/O Logic tab in software to assign one of 31 presets or sub presets to one of the eight digital logic input pins on the processor’s back panel. For Ashly WR-5 preset management, connect the WR-5 to the NE processor and use the WR-5 device in software to assign device and preset (or sub preset) controls. *Caution: A new preset may have dramatically different settings capable of damaging sound system components, so be careful not to recall the wrong preset while the system is on.*

The NE Processor Control Surface

Input Source

The input source tab displays all available inputs to the NE processor, and allows the user to select which input type and in what priority those inputs are to be used for each input channel pair. Also shown is the current master clock and sampling rate.

If a network audio card is installed, *and* the <Network Audio Matrix> item is selected under the device options menu, the network audio input is removed from the primary input source tab and instead placed in the resulting <Net Matrix Inputs> tab, along with the input DSP controls, allowing analog or AES/EBU inputs to be routed through the input DSP section and on out to the external digital audio network. Likewise, selecting the network audio matrix in the device options menu results in the appearance of the <Net Matrix Outputs>, allowing extraction of network digital audio channels for routing to the output DSP section and out to the NE processor’s analog output channels.

DSP Controls

All of the DSP editing is done in this tab, unless the <Network Audio Matrix> item is selected under the device options menu, in which case the DSP controls are split into input and output sections for interfacing with their respective audio networks. DSP controls include the following functions:

Dynamics: Brick Wall Limiter, Compressor, Ducker, and Gate

Gain: Gain, Gain with VCA, Remote Gain, and WR-5 Remote Gain

Equalization: Graphic 31, Parametric 10, 6, 4, and 2, and Feedback Suppressor

Crossover: 4 Way, 3 Way, 2 Way, HPF, and LPF

Delay: Speaker Delay, Delay

Tools: Audio Meter, Signal Generator

Extensive detailed information is available in NE software help for each of the DSP functions. Open a DSP function window and press F1 for help with that tool.

Metering

Three separate metering tabs are available for viewing across all channels the autoleveler, compressor/gate actions, or overall input and output signal levels. Note: In addition to the fixed meter tabs, individual meter control objects can be placed in the main software canvas and assigned to an input or output for a customized meter display.

Logic I/O

This tab is where the 12V digital logic I/O pins on the NE processor’s back panel are assigned their functions. Pins designated as logic inputs, upon contact closure with the logic ground, can recall a preset, utilize ‘push to talk’ to unmute a mic input and trigger a ducker, or be assigned to have no function. *Do not wire contact closure switches to an external ground.* If a logic input pin is unconnected, it will be internally pulled high. If actually driven by an external logic source, any voltage greater than +2.3VDC will be high.

Pins designated as logic outputs will issue either a logic high level (+12VDC at 10mA) or logic low level (0VDC sink at 100mA) when the GPO (general purpose output) function is selected. The high or low output state is a function of the currently loaded preset, or can be the result of a WR-5 button programmed to set the logic output to active high or active low. The logic outputs are current limited to sourcing no more than 10mA so that these outputs can be directly wired to LED indicators.

Security

The security tab allows several levels of user ID/password protected access. The default user ID is Admin, with no password until the principle operator, presumably the Admin, enters one. Up to six additional users can be added, each with their own password and access rights assigned by the Admin.

Network Properties

This is where to find the exact hardware and firmware configuration of a specific device, as well as device network attributes. Also found here is an <Identify Device> button which flashes the Com LED on the face panel when clicked.

10. REMOTE CONTROL

WR-5 Programmable Zone Controller (Remote Data)

The WR-5 is a microprocessor based remote control unit which can be used with the NE processor. The WR-5 is designed to fit into a standard electrical wall box. Up to four WR-5 remotes can be phantom powered from one processor. Additional remotes can be powered by using the Ashly RPS-18 remote power supply. Each of six buttons on the WR-5 can be programmed to engage one of the following functions. listed below. The up/down buttons are used to control the designated parameter, if applicable

- 1) Preset Recall
- 2) Preset Scroll Mode
- 3) Gain Control
- 4) Channel Engage/Mute
- 5) Zone Source Selection
- 6) Logic Output Active High
- 7) Logic Output Active Low
- 8) Matrix Mixer

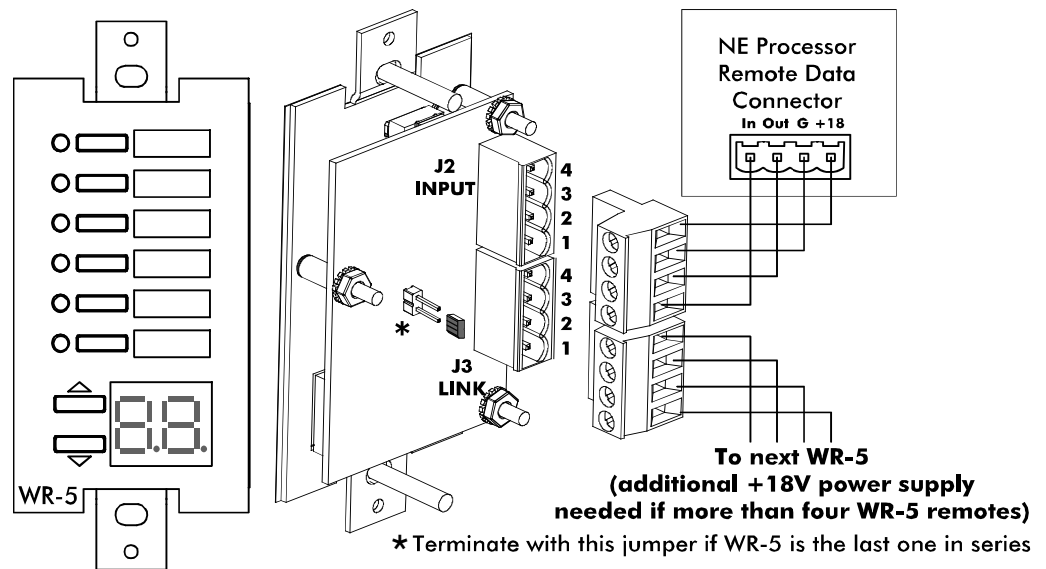

Ashly WR-5 Programmable Controller

Programming of each WR-5 button is done from NE software when the WR-5 is wired to its host NE processor through the remote data connector, and the processor is connected to a PC via Ethernet. Each WR-5 has its own identifying property and is thus uniquely represented with its own software control surface, within which the button actions are programmed. Click the <Identify Remote> button to find a physical WR-5. As mentioned, the Ashly RPS-18 power supply must be used to provide power for any WR-5 units beyond four in series. Additionally, a provided jumper must be placed on the last and only the last WR-5 in a series, and even if there is only one WR-5 used (see drawing).

RD-8C or RW-8C Remote Control (Remote Data)

A second microprocessor based desktop controller, the Ashly RD-8C (or RW-8C wall mount), is an eight channel level controller that uses slide faders for individual channel and master level control and mute. The RD-8C is wired to the four pin Data Input euroblock connector on the back panel. Only one RD-8C can be wired to a NE processor. *NOTE: When an RD-8C is used, no other data port based remotes can be used.*

In the software DSP control section, a remote gain function can be placed in any input or output and mapped to any of the slide faders on an RD-8C for remote level control of that channel. The RD-8C uses an XLR jack, while the RW-8C uses a euroblock connector to wire to the NE processor (see wiring diagram).

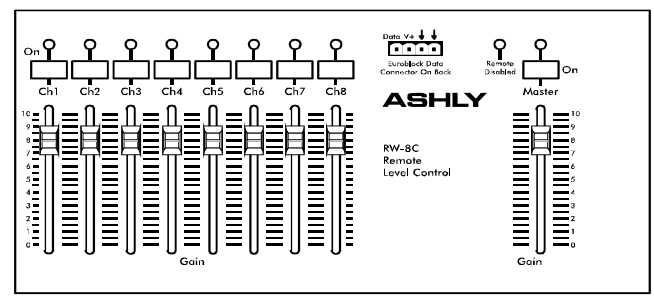
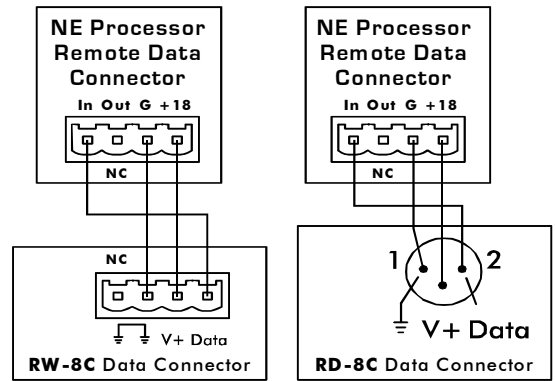

Ashly RW-8C Remote Level Controller

WR-1 Remote Level Control (5VDC)

Individual input or output channels can have remote level control using a potentiometer assembly such as the Ashly WR-1 and four conductor wire. The WR-1 is a dual potentiometer remote volume control designed to fit in a standard electrical wall box. Each volume control is connected to a terminal block on the WR-1 circuit board, which in turn must be wired to the processor back panel euroblock connector labeled "5VDC Remote Control" as shown. *Do not connect the WR-1 remote level control ground to any other external grounds.*

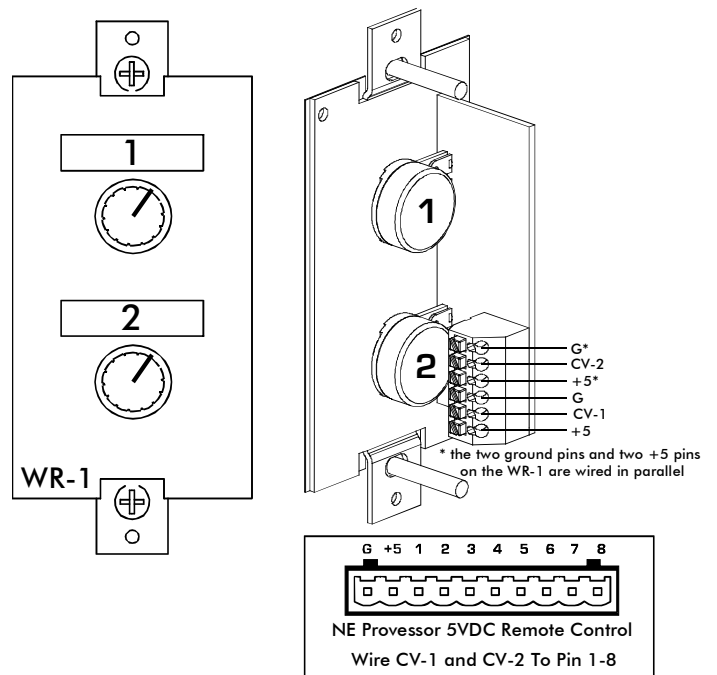

Ashly WR-1 Remote DC Level Controller

11. SPECIFICATIONS

<u>Overall Sonic Performance</u>	<u>Analog in, digital out</u>	<u>Digital in, analog out</u>	<u>Analog in, analog out²</u>	<u>Digital in, digital out</u>
Frequency Response, 20 Hz – 20 kHz:	+/- 0.1 dB	+/-0.25 dB	+/- 0.25 dB	NA ³
Dynamic Range, 20Hz-20kHz, unweighted:	> 115 dB	> 114 dB	> 114 dB	NA ³
THD+N, 1kHz, +20dBu analog (-1dBFS digital): <	0.001 %	< 0.002 %	< 0.002 %	< 0.00001 %
Latency at 48 KHz (96 kHz) ⁴ :	1.42 ms (0.71 ms)	0.90 ms (0.45 ms)	2.21 ms (1.11 ms)	0.10 ms (0.05 ms)

Notes:

- 1) Measured 20 Hz – 20 kHz unweighted using AES17 LPF at 48 kHz sample rate.
- 2) Analog in to analog out measured using internal master clock.
- 3) Zero noise or signal amplitude variation introduced in digital domain.
- 4) Latency of network audio link is additional to latency of digital audio processor.

<u>Audio Inputs</u>	<u>Analog Line/Mic</u>	<u>AES/EBU Digital</u>
Input Type:	Active balanced Euroblock	Transformer balanced female XLR
Input Impedance:	20k ohms	110 ohms
Max Input Level:	+20 dBu	7.0 Vpp

<u>Audio Outputs</u>	<u>AES/EBU Transformer balanced male XLR</u>
Output Type:	Servo-balanced Euroblock
Output Impedance:	20 ohms
Max Output Level:	+20dBu

Word Clock

Input/output Type:	75 ohm BNC
Lock Range:	48 kHz +/- 4%, 96 kHz +/- 4%
Input Impedance:	Selectable 75 ohm or high-impedance
Input Voltage Range:	1.0 Vpp – 7.0 Vpp
Output Impedance:	75 ohm
Output Level:	5.0 Vpp nominal, unterminated

Master Clock

Sources:	Audio network, Word clock, AES/EBU, Internal crystal clock
Modes:	Prioritized auto switching or manual

Digital Audio Hardware

Samples Rates:	48 kHz, 96 kHz
DSP Processing:	32-bit floating-point Sharc processor array
Audio Input Source Selection:	Selectable in adjacent channel pairs from analog, digital, or network inputs
Network Audio Routing:	Selectable between input/output or internal to matrix mixer
Digital Audio Output Jitter:	0.5 ns average, 1.0 ns peak

Digital Control

Ethernet Control	Standard RJ45 10/100 Ethernet with auto-configuration
RS-232 Control	Standard female Dsub9 jack
4-pin active remote	4-pin Euroblock for phantom-powered bi-directional remotes
Logic Inputs	9-pin Euroblock for (8) assignable 5V logic inputs
Logic Outputs	Shared with logic inputs. +12V at 10mA output high, 100mA input low

Analog Control

Remote attenuators	10-pin Euroblock for (8) assignable 0-5 VDC passive remote attenuators
--------------------------	--

DSP Functions

Dynamics

<u>Brick Wall Limiter</u>	<u>Autoleveler</u>
Threshold:	-20dBu to +20dBu
Ratio:	infinite
Attack:	0.2ms/dB to 50 ms/dB
Release:	5ms/dB to 1000ms/dB
<u>Compressor</u>	<u>Target Level:</u>
Threshold:	-20dBu to +20dBu
Ratio:	1.2:1 to infinite
Attack:	0.2 to 50ms
Release:	5ms/dB to 1000ms/dB
Detector:	Peak/Average
	<u>Action:</u>
	gentle, normal, aggressive, user defined
	<u>Maximum Gain:</u>
	0dB to +15dB
	<u>Ratio:</u>
	1.2:1 to 10:1
	<u>Threshold Below Target:</u>
	-30dB to 0dB
	<u>Gain Increase Rate:</u>
	5ms/dB to 1000ms/dB
	<u>Hold Time:</u>
	0-6 sec

Ducker

Ducking Type: high/low priority, trigger, filibuster, ducked at input, ducked at mixer
Trigger Threshold: -80dBu to +20 dBu
Ducking Release: 5ms/dB to 1000ms/dB
Ducking Depth: 0dB to -30dB

Gate

Modes: Normal, lock-out, selectable frequency key
Frequency Key Filter: Band-pass filter
Key Filter Range: 20 Hz – 20 kHz, 1/64 oct. to 4 oct.
Threshold: -80dBu to +20dBu
Range: off, 100dB to 0dB
Attack: 0.2ms/dB to 50 ms/dB
Release: 5ms/dB to 1000ms/dB

Gain

Normal Gain Control: +12 dB to -50dB in 0.5 dB increments, then OFF. Selectable polarity
Gain with Digital VCA: 4 assignable groups, +12 dB to -50dB, then OFF. Selectable polarity
Remote Gain Control: 8 assignable 0-5V DC controls
Assignable active RD-8C control
WR-5 Remote Gain: Remote Gain 0 to -50dB, Mute, assignable to any channel

Equalization

Graphic EQ

Bands: 31
Filter Types: Constant Q, Proportional Q
Bandwidth Range: 0.499 Oct to 0.25 Oct

Parametric EQ

Type: 10-band, 6-band, 4-band, and 2-band available on every input and output

Parametric Filters

Frequency Range: 20Hz to 20KHz
Level Range: +15dB to -30dB
Bandwidth Range: 0.016 Oct. to 3.995 Oct.

6/12dB Hi/Low Shelf Filters

Frequency Range: 20Hz to 20KHz
Level Range: +15dB to -15dB

All Pass Filter

Frequency Range: 20Hz to 20KHz

Variable Q HP/LP Filters

Frequency Range: 20Hz to 20KHz
Q Range: 0.267 to 3.047

Notch Filter

Frequency Range: 20Hz to 20KHz
Bandwidth Range: 0.016 to 3.995 Oct.

Bandpass Filter

Frequency Range: 20Hz to 20KHz
Bandwidth Range: 0.016 to 3.995 Oct.

Feedback Suppressor

Filters: 12
Filter Types: Notch, Parametric
Feedback detection freq. range: .. 5 Hz – 20 kHz
Bandwidth Range 0.016 to 3.995 Oct.
Filter Modes: Floating, restricted, manual, locked
Sensitivity Control: 5 levels
Floating Filter Reset: 5 seconds to 24 hours

Crossover

4 Way, 3 Way, 2 Way on Outputs Only.

Low-Pass and High Pass Filters on Inputs and Outputs

Type: Bessel, Butterworth, Linkwitz-Riley,

Notched Linkwitz-Riley

Bessel: 12/18/24/48 dB/oct

Butterworth: 12/18/24/48 dB/oct

Linkwitz-Riley: 12/24/48 dB/oct

Notched Linkwitz-Riley: 4th, 8th order

Frequency: off, 20Hz-20KHz

Delay

Speaker Delay

At 48 kHz: 58.65 ms in 20 uS increments

At 96 kHz: 29.32 ms in 10 us increments

Long Delay

At 48 kHz: 1365.31 ms in 20 us increments

At 96 kHz: 682.65 ms in 10 us increments

Tools

Signal Generator

Signal Types Pink Noise, White Noise
Sine Wave (20Hz to 12KHz)

Level Range Off, -50dBu to +20dBu

Level Meters

Range 0dBFS to -80dBFS

Matrix Mixer

Gain range: +12 dB to -50dB in 0.5 dB increments, then OFF

Power Requirements: 100 – 240 VAC, 50 – 60 Hz, 70 W maximum

Shipping weight: 14 lbs. (6.35 kg)

Dimensions: 19.0" L x 3.5" H x 8.5" D
(48.26 cm x 8.89 cm x 21.59 cm)

Environmental: 40-120 deg. F, (4-49 deg. C) noncondensing

Linking

All functions can be linked to 1 of 8 link groups

12. Troubleshooting Tips

No Ethernet Communications

Is there LED activity on the back panel RJ-45 Ethernet connector? Is the ethernet cable good? Is good ethernet signal getting to the point of application? (test by plugging in a laptop) Is your firewall turned on? Do you have a local area connection enabled? Do you have a secondary WiFi connection enabled?

No Audio Meter Activity

Is the input wiring correct? Is the proper input source selected? Is the channel muted, gated, or ducked? Are all gain stages properly set? Is the matrix mixer section properly routed? Do you have signal if you disconnect all WR-1 and/or RD-8C units?

No Audio Output

Is the output muted? Are the DSP output meters showing signal present? Are your inputs routed to, turned up in, and unmuted in the matrix mixer section of the output? Are crossover filters mistakenly set to eliminate any pass band?

Distorted Sound

Do you see clip indicator lights in the audio chain? If the meter scales are set to dBFS, 0dBFS is the clipping point.

WR-5 Doesn't Work

Is the wiring correct? Is the two pin jumper installed on the back side of the last WR-5 in series, even if there is only one WR-5? If there are more than four WR-5 units in series, an external power supply must be used capable of providing +18V at 25mA per WR-5. Does the WR-5 appear in the Protea Software network drop down menu underneath the host NE processor? Are WR-5 functions properly defined in the WR-5 and/or NE Processor?

RD-8C or RW-8C Doesn't Work

Is the wiring correct? Are proper RD8-C fader assignments made in the DSP Gain > Remote Gain > RD8C Controls tool boxes for each applicable input or output channel requirement? No other active remote control units can be used when using an RD-8C.

WR-1 Doesn't Work

Is the wiring correct? Are proper control assignments made in the DSP Gain > Remote Gain > Rear Panel Remote Level Controls tool boxes for each applicable input or output channel requirement?

How Do I Use RS-232?

RS-232 is available on the NE processor as a means for non-ethernet equipment to communicate control information to the NE processor. An RS-232 implementation reference for the NE processor is available on the Ashly web site. You cannot program any serial data remote using RS-232. Only Ethernet connected NE processors can be used to program the WR-5 and RD-8C.

Optional Input/Output Modules
(Factory Installed)

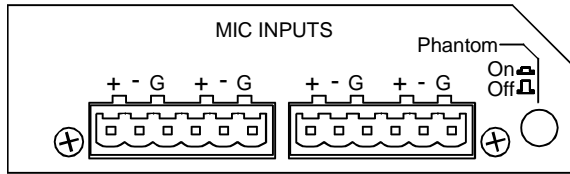

Four Channel Mic Input
with Phantom Power

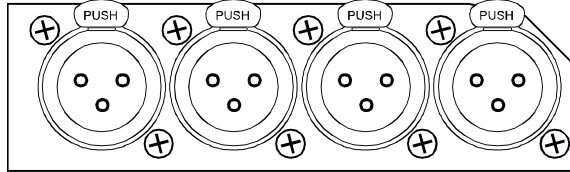

Eight Channel AES/EBU Input
(four stereo digital inputs)

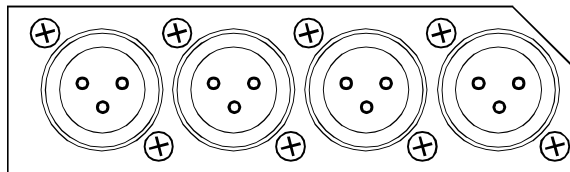

Eight Channel AES/EBU Output
(four stereo digital outputs)

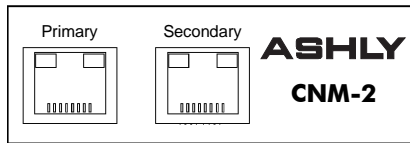

CobraNet Audio Network
Input/Output

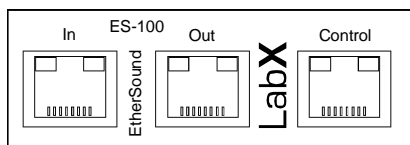

EtherSound Audio Network
Input/Output

(See page 7 for further option details)

13. Ashly Audio Inc. LIMITED WARRANTY (USA ONLY)

(Other countries please contact your respective distributor or dealer.)

For units purchased in the USA, warranty service for this unit shall be provided by ASHLY AUDIO, INC. in accordance with the following warranty statement.

ASHLY AUDIO, INC. warrants to the owner of this product that it will be free from defects in workmanship and materials for a period of FIVE years from the original-date-of-purchase. ASHLY AUDIO INC. will without charge, repair or replace at its discretion, any defective product or component parts upon prepaid delivery of the product to the ASHLY AUDIO, INC. factory service department, accompanied with a proof of original-date-of-purchase in the form of a valid sales receipt. This warranty gives you specific legal rights, and you may also have other rights, which vary from state to state.

EXCLUSIONS: This warranty does not apply in the event of misuse, neglect, or as a result of unauthorized alterations or repairs made to the product. This warranty is void if the serial number is altered, defaced, or removed. ASHLY AUDIO, INC. reserves the right to make changes in design, or make additions to, or improvements upon, this product without any obligation to install the same on products previously manufactured.

Any implied warranties, which may arise under the operation of state law, shall be effective only for FIVE years from the original-date-of-purchase of the product. ASHLY AUDIO, INC. shall be obligated to only correct defects in the product itself. ASHLY AUDIO, INC. is not liable for any damage or injury, which may result from, or be incidental to, or a consequence of, such defects. Some states do not allow limitations on how long an implied warranty lasts, or the exclusion, or limitation of incidental or consequential damages, so the above limitations or exclusions may not apply to you.

OBTAINING WARRANTY SERVICE:

For warranty service in the United States, please follow this procedure:

1) Return the product to ASHLY AUDIO, INC. freight prepaid, with a written statement describing the defect and application that the product is used in. ASHLY AUDIO, INC. will examine the product and perform any necessary service, including replacement of defective parts, at no further cost to you.

2) Ship your product to:

ASHLY AUDIO, INC.

Attention: Service Department

847 Holt Road

Webster, NY 14580-9103



ASHLY AUDIO INC. 847 Holt Road Webster, NY 14580

Phone: (585) 872-0010 Fax: (585) 872-0739

Toll Free (800) 828-6308 www.ashly.com