

An Ashly Audio, Inc. White Paper



847 Holt Road  
Webster, NY 14580-9103  
800-828-6308  
[www.ashly.com](http://www.ashly.com)

## **Ashly Power-over-Ethernet (PoE) Product Compliance**

*Richard Frank Kerr, Ph.D.  
Senior Development Engineer  
October 28, 2011*

## 1.0 PoE Definitions and Policy

*Power Sourcing Equipment (PSE):* A device on the network that supplies electrical power on the Ethernet cable.

*Powered Device (PD):* A device on the network that consumes the power supplied by the PSE. The three Ashly products listed in the PoE Compliance Matrix are PD devices.

*Alternative A Operation:* For 10/100 Base-T networks the PoE delivers phantom power on the four conductors comprising the two data pairs (pins 1 and 2, and pins 3 and 6).

*Alternative B Operation:* For 10/100 Base-T networks the PoE delivers phantom power on the four conductors comprising the two spare pairs (pins 4 and 5, and pins 7 and 8).

*Alternative A versus Alternative B Selection:* The PSE determines whether power Alternative A or Alternative B will be used. The PD must accommodate the PSE Alternative choice. In addition, the PD cannot be designed to implement only Alternative A or Alternative B.

*1000 Base-T PoE:* For 1000 Base-T networks the PoE delivers phantom power on the eight conductors comprising the two data pairs and the two spare pairs (pins 1 through 8).

*Endspan:* An Ethernet switch that also functions as a PSE to supply electrical power for the PoE. This is referred to as a PoE switch.

*Midspan:* A device added to the network between a non-PoE switch and the PD, to serve as the PSE. Midspans are used when there is no desire to replace a non-PoE enabled Ethernet switch, and only PoE needs to be added to the network.

## 2.0 Ashly Product PoE Compliance Matrix

Ashly Product Name	IEEE 802.3af (2003) Compliant	IEEE 802.3at (2009) Type 1 Compliant	IEEE 802.3at (2009) Type 2 Compliant	Device Power Requirements (Watts)	External power Connector if PoE is Unavailable
<b>neWR-5</b>	Yes (Class 1 Reported)	Yes (Class 1 Reported)	Given the absence of 'layer 2' PoE Ethernet communications from the Ashly device, the 802.3at PSE will automatically function as a Type 1 device. *	2 Watts maximum at 15 - 48 VDC	Yes
<b>FR-8</b>	Yes (Class 1 Reported)	Yes (Class 1 Reported)		2 Watts maximum	No (PoE only)
<b>FR-16</b>	Yes (Class 1 Reported)	Yes (Class 1 Reported)		2 Watts maximum	No (PoE only)

\* IEEE 802.3at Type 2 operation utilizes both 'layer 1' and 'layer 2' communications in the Ethernet protocol stack, whereas 802.3af and 802.3at Type 1 devices are restricted to 'layer 1'. The Ashly PoE power controller utilizes a communications protocol that uses ONLY 'layer 1' communications, therefore Ashly PoE products automatically default to Type 1 operating mode.

The midspan PoE power injectors tested at the Ashly facility for supplying electrical power to the Ethernet cable are: (1) EnGenius EPE-5818af, and (2) TRENDnet TPE-101I. Both of these power injectors are 802.3af compliant. This statement is not intended as the exclusive list of midspan power injectors that will work with Ashly equipment. Rather, Ashly PoE enabled products will work with any midspan power injector that is 802.3af and/or 802.3at Type 1 compliant.

### 3.0 IEEE 802.3af and IEEE 802.3at Parameter Summary

**Table 2: Standard PoE Parameters and Comparison**

Property	802.3af and 802.3at Type 1	802.3at Type 2
Power available at PD	13.0 W	25.50 W
Maximum power delivered by PSE	15.40 W	34.20 W
Voltage range (at PSE)	44.0–57.0 V	50.0–57.0 V
Voltage range (at PD)	37.0–57.0 V	42.5–57.0 V
Maximum current	350 mA	600 mA per Alternative A or B
Maximum cable resistance	20 $\Omega$ (Category 3)	12.5 $\Omega$ (Category 5)
Power management	Three power class levels negotiated at initial connection	Four power class levels negotiated at initial connection or 0.1 W steps negotiated continuously
Derating of maximum cable ambient operating temperature	None	5°C with one Alternative (two pairs) active
Supported cabling	Category 3 and Category 5	Category 5
Supported modes	Alternative A, Alternative B	Alternative A, Alternative B

The parameters values specified in Tables 2 and 3 are per port in a multi-port PSE device.

**Table 3: Available Power per PoE Class**

Class	Usage	Classification Current [mA]	Maximum Power [Watt]	Class Description
<b>0</b>	Default	0 – 4	<b>13.0</b>	Classification unimplemented
<b>1</b>	Optional	9 – 12	<b>3.84</b>	Very low power
<b>2</b>	Optional	17 – 20	<b>6.49</b>	Low power
<b>3</b>	Optional	26 – 30	<b>13.0</b>	Mid power
<b>4</b>	Valid for 802.3at (Type 2) devices, not allowed for 802.3af devices	36 – 44	<b>25.50</b>	High power

Tables 2 and 3 contents were obtained from the IEEE 802.3at-2009 Standard Documentation

## 4.0 Generalized PoE Discussion

### 4.1 Commercial Designations of PoE PSE Equipment: PoE, PoE+, PoE Ultra, and PoE Ultimate

The IEEE 802.3at-2009 standard specifies up to 25.5 W of power may be delivered to the Ethernet powered device. The 2009 standard prohibits a powered device from using all four pairs for power. Some vendors have announced products that claim to be compatible with the 802.3at standard and offer up to 51 W of power over a single cable by utilizing all four pairs in the Category 5 cable. Thus, commercial product designations such as PoE Ultra and PoE Ultimate can deliver more than 25.5 W to a powered device, and these higher current limits are prohibited in both 802.3af and 802.3at.

### 4.2 Ethernet Cable Categories and Characteristics

“Type 1 operation (i.e. 802.3af and 802.3at Type 1) adds no significant requirements to the cabling. Type 2 operation (i.e. 802.3at Type 2) requires ISO/IEC 11801:1995 Class D or better cabling and a derating of the cabling maximum ambient operating temperature. The clause does not address the operation of 10GBASET.” <sup>[IEEE 802.3at-2009 Standard Document]</sup>

**Table 4: Ethernet Cable Categories and Characteristics**

Category	Type	Max Data Rate	Max Length	Characteristic Impedance at 100 MHz	AWG	Loop Resistance $\Omega/m$	LAN Applications
Cat3	UTP	16 MHz	100m				10Base-T
Cat5	UTP	100MHz	100m	100 ohms $\pm 15\%$	24	$2 \times 0.094 = 0.188$	100Base-T
Cat5e	UTP	100MHz	100m	100 ohms $\pm 15\%$	24	$2 \times 0.099 = 0.198$	
Cat6	UTP	250MHz	100m	100 ohms $\pm 15\%$	23	$2 \times 0.099 = 0.198$	
Cat7	ScTP	600MHz	100m	100 ohms	23	$2 \times 0.074 = 0.148$	

UTP: Unshielded Twisted Pair

ScTP: Screened Twisted Pair

Table 4 contents derived from:

<http://discountcablesusa.com/ethernet-cables100.html>

[http://en.wikipedia.org/wiki/Category\\_5\\_cable](http://en.wikipedia.org/wiki/Category_5_cable)

<http://www.3m-net.de/quante/pdf/english/Cat%207%20cable%20100%20Ohm.pdf>

[http://www.3m-net.de/quante/pdf/english/Cat\\_6\\_cable%20UTP.pdf](http://www.3m-net.de/quante/pdf/english/Cat_6_cable%20UTP.pdf)

[http://www.3m-net.de/quante/pdf/english/Cat\\_5e\\_cable.pdf](http://www.3m-net.de/quante/pdf/english/Cat_5e_cable.pdf)

4.3 PoE Wiring Diagrams for Alternative A or Alternative B Operation [IEEE 802.3at-2009 Standard Document]

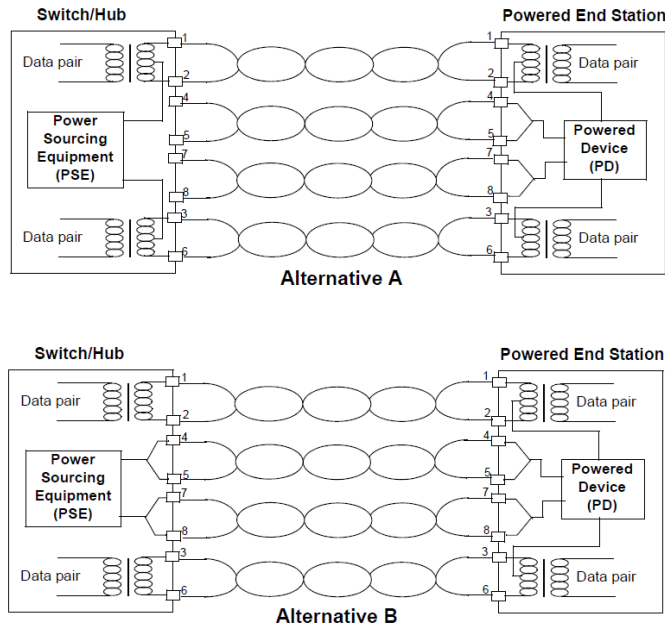

Figure 1: 10 BASE-T/100 Base-T Endpoint PSE location overview

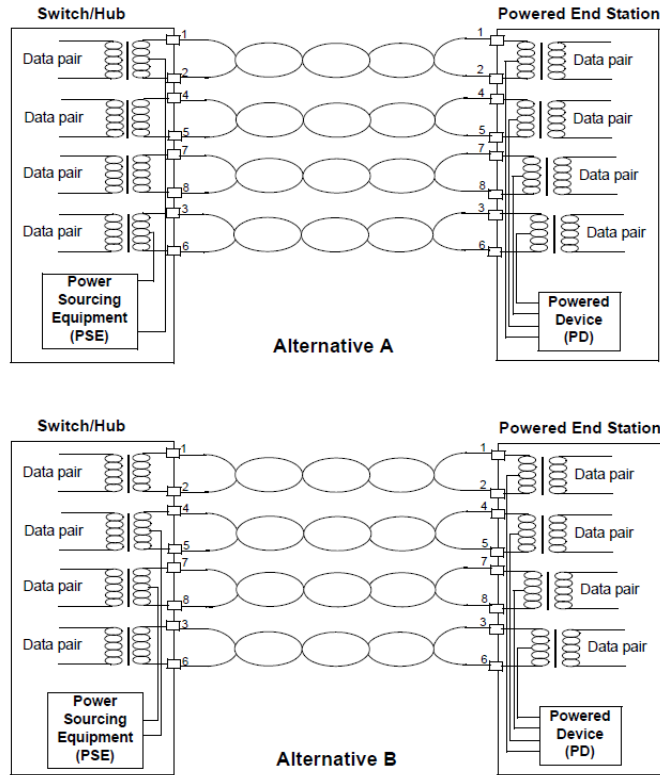
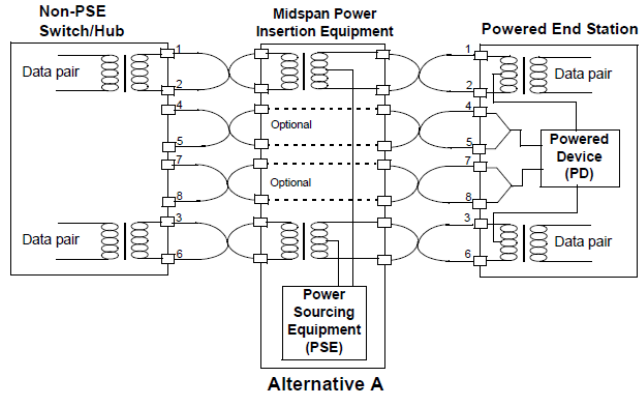
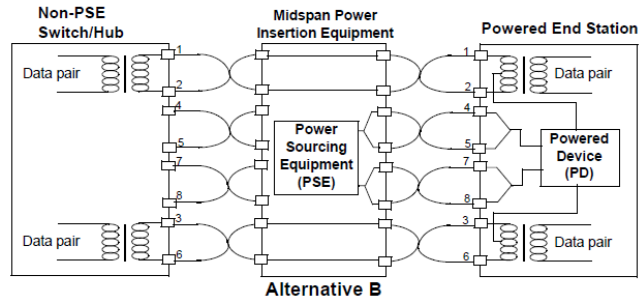

Figure 2: 1000 Base-T Endpoint PSE location overview



Alternative A



Alternative B

Figure 3: 10 BASE-T/100 Base-T Midspan PSE location overview

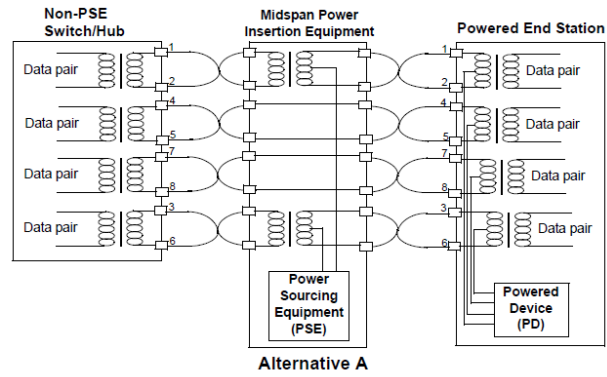

Alternative A

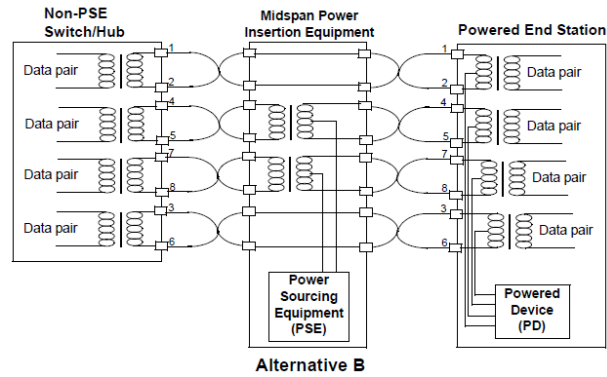

Alternative B

Figure 4: 1000 Base-T Midspan PSE location overview